

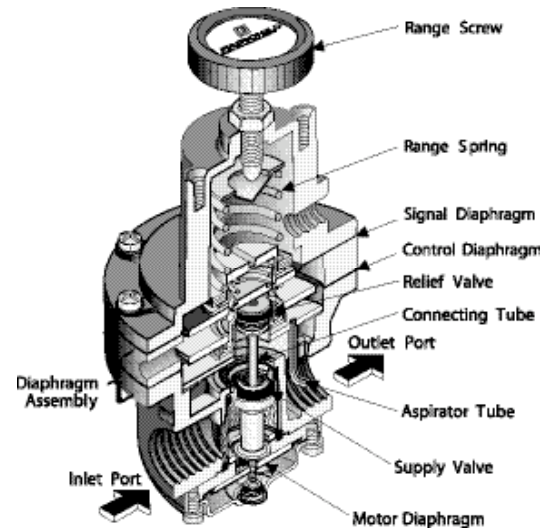

Features

- Control sensitivity of 1" water column allows use in precision applications.
- Large Supply and Exhaust Valves provide high forward and exhaust flows.
- Soft Supply and Exhaust Valve seats minimize air consumption.
- A balanced Supply Valve minimizes the effect of supply pressure variation.
- An Aspirator Tube compensates downstream pressure droop under flow conditions.
- A separate Control Chamber isolates the diaphragm from the main flow to eliminate hunting and buzzing.
- Unit construction lets you service the Model 1500A without removing it from the line.



Operating Principles

The output of the relay is the sum of the spring bias, set with the Range Screw, plus a pneumatic input signal. ($P_o = P_s + K$); where P_o is output pressure, P_s is signal pressure, and K is the spring constant set by the Range Screw. The signal pressure exerts a force against the top of the Signal Diaphragm that creates a downward force on the Diaphragm Assembly and opens the Supply Valve. Output pressure flows through the Outlet Port and the Aspirator Tube to the Control Chamber where it creates an upward force on the bottom of the Control Diaphragm.

When the setpoint is reached, the forces of the signal pressure and the Range Spring that act on the top of the Signal Diaphragm, balance with the force of the output pressure that acts on the bottom of the Control Diaphragm to close the Supply Valve.

When the output pressure increases above the setpoint, the Diaphragm Assembly moves upward to close the Supply Valve and open the Exhaust Valve. Because the Poppet Valve is closed, pressure flows down the Control Tube to the bottom of the Motor Diaphragm. This pressure keeps the Supply Valve tightly closed while in the exhaust mode. The Poppet Valve opens and excess output pressure exhausts through the Vent in the side of the unit until it reaches the setpoint.

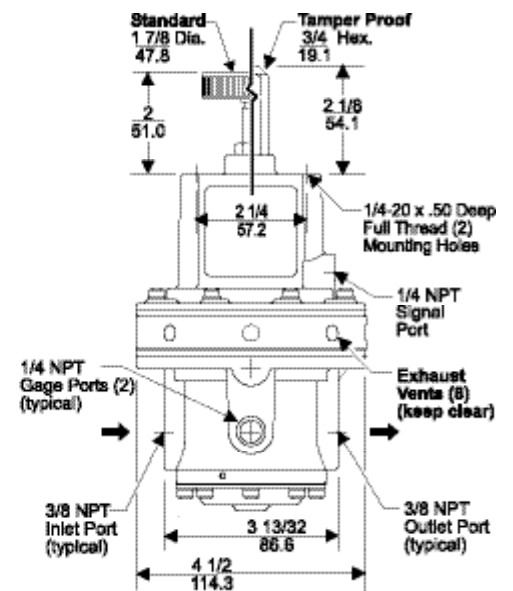
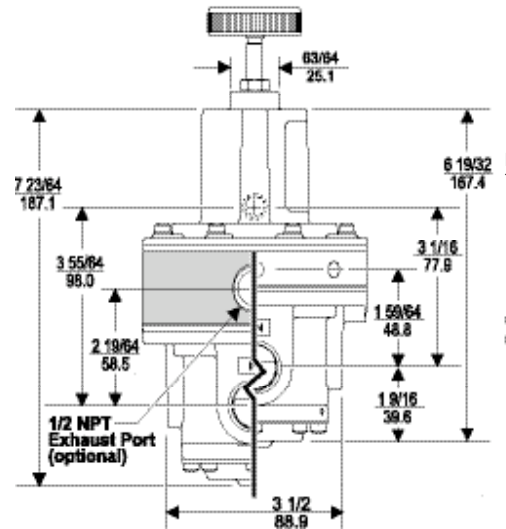

Model 1500A

Technical Information

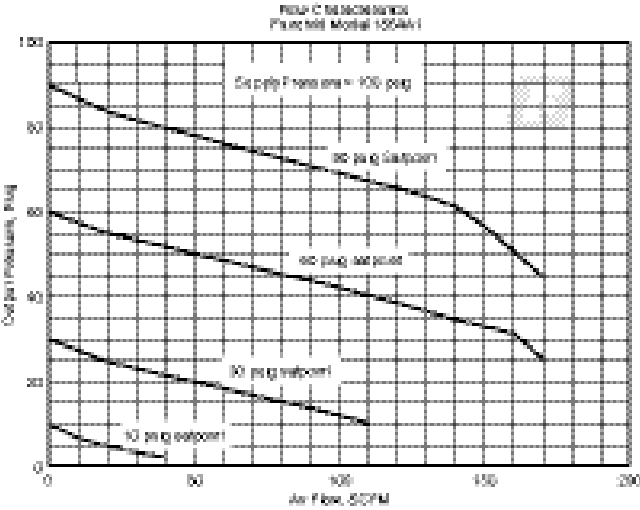

Specifications

Supply Pressure

250 psig, [17.0 BAR], (1700 kPa) Maximum

Flow Capacity (SCFM)

150 (255 m³/HR) @ 100 psig, [7.0 BAR], (700 kPa) supply & 20 psig, [1.5 BAR], (150 kPa) setpoint

Exhaust Capacity (SCFM)

40 (68 m³/HR) where downstream pressure is 5 psig, [.35 BAR], (35 kPa) above 20 psig, [1.5 BAR], (150 kPa) setpoint

Signal or Output Pressure

150 psig, [10.0 BAR], (1000 kPa) Maximum

Supply Pressure Effect

Less than 0.1 psig, [.007 BAR], (.7 kPa) for 100 psig, [7.0 BAR], (700 kPa) change in supply pressure

Sensitivity

1" (2.54 cm) Water Column

Ambient Temperature

-40° F to +200° F, (-40° C to +93° C)

Materials of Construction

Body and Housing Aluminum
Diaphragms Nitrile on Dacron
Trim Zinc Plated Steel, Brass

Catalog Information

Catalog Number

1 5 A

Pressure Range

psig	[BAR]	(kPa)	
0-10	[0-0.7]	(0-70)	2
0.5-30	[0.03-2]	(3-200)	3
1-60	[1-4.0]	(10-400)	4
2-150	[0.15-10]	(15-1000)	6

Pipe Size

3/8" NPT	3
1/2" NPT	4
3/4" NPT	6

Options

Tapped Exhaust	E
Tamper Proof	T
BSPT (Tapered)	U

Installation

For installation instructions, refer to the *Fairchild Model 1500A Positive Bias Relay Installation, Operation and Maintenance Instructions, IS-3001500A*.

D
Model
1500A