



Features

- 2 Stage Pilot Operation allows precise control of set points.
- 14 SCFM flow capacity in a small size unit.
- Low air consumption preserves air and other costly gases.
- Compact size permits installation where space is limited.
- Available in 1/8", 1/4" and 3/8" port sizes.

Operating Principles

The Model 85D Multi-Stage Biasing Relay is a precision control combining the sensitivity of a precision pressure regulator with positive biasing capability. This compact, pilot-operated device offers unusually high output capacity with minimal air consumption, while providing excellent protection against supply or output pressure variations.

The versatile Model 85D is recommended for use in systems requiring precision pressure maintenance and instrument biasing, in dead end service and instrument panel supply applications.

The basic mathematical expression for the Model 85D is $PO = PS + K$ where PO is output pressure, PS is signal pressure and K is the spring constant.

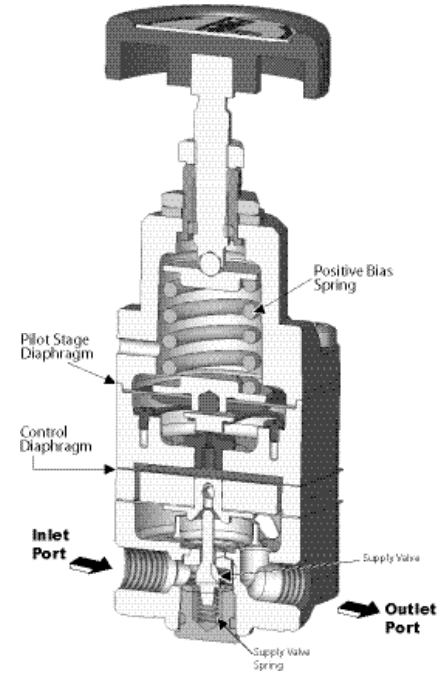

Model 85D

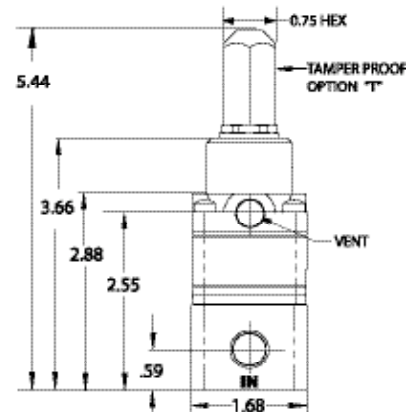
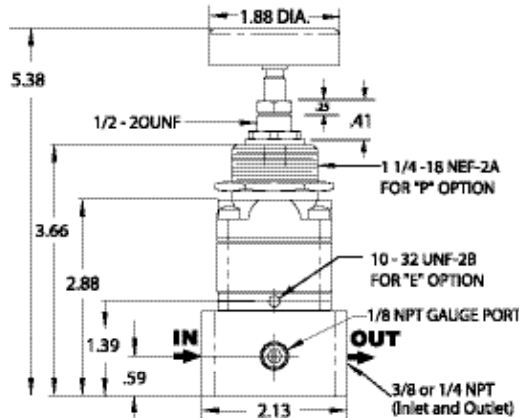
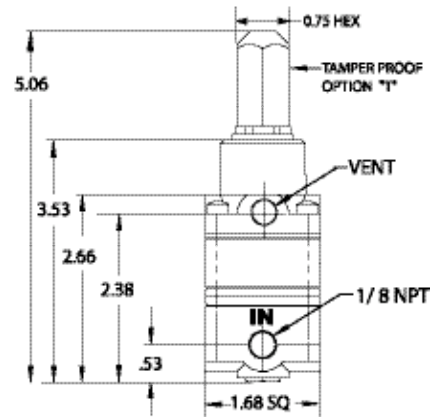
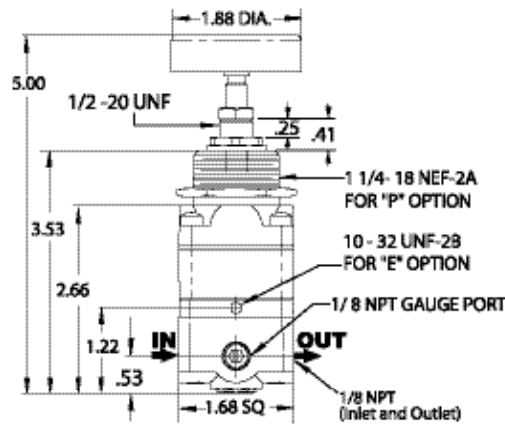

Model 85D Multi-Stage Biasing Relay

Specifications

Maximum Supply Pressure

250 psig, [17.5 BAR], (1750 kPa)

Recommended Operating Supply Pressure

150 psig, [10 BAR], (1000 kPa)

Maximum Signal or Output Pressure

150 psig, [10 BAR], (1000 kPa)

Flow Capacity

14 SCFM (23.8 m³/HR) @ 100 psig, [7.0 BAR], (700 kPa) supply, 20 psig, [1.5 BAR], (150 kPa) setpoint

Exhaust Capacity

2.5 SCFM (4.25 m³/HR) where downstream pressure is 5 psig, [.35 BAR], (35 kPa) above setpoint

Supply Pressure Effect

Less than 0.2 psig, [.014 BAR], (1.4 kPa) for 100 psig, [7.0 BAR], (700 kPa) change in supply pressure

Pressure Change Under Flow Conditions

Less than 0.1 psig, [.007 BAR], (.7 kPa) from dead end service to 10 SCFM (17 m³/HR)

(Set pressure 10 psig, [.7 BAR], (70 kPa), supply pressure 100 psig, [7.0 BAR], (700 kPa)

Air Consumption

Less than .1 SCFM (.17 m³/HR)

Ambient Temperature Limits

-40°F to +200°F, (-40°C to 93.3°C)

Materials of Construction

BodyAluminum
 TrimAluminum, Stainless Steel, Brass
 DiaphragmsBuna N and Dacron

Catalog Information

Catalog Number

8 5



Pressure Range

psig	[BAR]	(kPa)	
0-20	[0-1.5]	(0-150)	53 ¹
1-60	[0.07-4]	(7-400)	54 ¹
1-100	[0.07-7]	(7-700)	55 ¹
0-20	[0-1.5]	(0-150)	63 ²
1-60	[0.07-4]	(7-400)	64 ²
1-100	[0.07-7]	(7-700)	65 ²

Pipe Size

1/8" NPT	1
1/4" NPT	2
3/8" NPT	3

Options

Tapped Exhaust	E
Bonnet Mounting	P
Tamper Proof	T
BSPT (Tapered)	U

¹ 1/8" NPT Pipe Size only.

² 1/4" or 3/8" NPT Pipe Size only.

Service Kit

A Service Kit is available for the Model 85D Multi-Stage Biasing Relay, refer to the *Installation, Operation and Maintenance Instructions*, IS-3000085D.

