











Photo	Type	Series	Description	Main Specifications
	Pressure Control	OR	Relief Modular Valve	13.2 - 21.2gpm, 3571psi
	Pressure Control	ORO	Brake Modular Valve	5.3 - 7.9gpm, 114 to 3000, 3571psi
	Pressure Control	ORD	Direct Relief Modular Valve	5.3 - 7.9gpm, 114 to 3000, 3571psi
	Pressure Control	OG	Pressure Reducing Modular Valve	10.6 - 21.2gpm, 3571psi
	Pressure Control	OQ	Sequence Modular Valve	10.6 - 21.2gpm, 3571psi
NA	Pressure Control	OCQ	Counter Balance Modular Valve	10.6 - 21.2gpm, 2000psi
	Pressure Control	OW	Modular Type Pressure Switch	13.2gpm, 3571psi
	Flow Control	OY/OCY	Flow Regulator Modular Valve	13.2 - 26.4gpm, 3571psi
	Flow Control	OF/OCF	Flow Control Modular Valve	5.3 - 15.8gpm, 3000, 3571psi
	Check Valves	OC/OCV	Check Modular Valve	13.2 - 26.4gpm, 3571psi
	Check Valves	OCP	Pilot Operated Check Modular Valve	13.2 - 26.4gpm, 3571psi
NA	Valve Installation Bolt List	OTH/OTD	NA	NA

Flow Regulator Modular Valve

13.2 to 26.4gpm
3571psi



Features

- ① This modular valve is used to control actuator speed and for other flow control valve applications.
- ② A wide range of models are available for A and B port control, A or B port control, and P or T port control.
- ③ Maximum Operating Pressure: 25MPa {3571psi}

Specifications

Model No.	Nominal Diameter (Size)	Maximum Working Pressure MPa{psi}	Maximum Flow Rate ℓ /min{gpm}	Cracking Pressure of Check Valve MPa{psi}	Weight kg	Gasket Surface Dimensions
OY-G01-T-20	1/8	25{3571}	50 (13.2)	-	1.0	ISO 4401-03-02-0-94
OCY-G01-P-20				0.04{5.7}	1.0	
OCY-G01-W-X-20 A B				0.08{11.4}	1.3	
					1.2	
OCY-G01-W-Y-20 A B				0.08{11.4}	1.3	
		1.2				
OCY-G03-P-J50	3/8	25{3571}	100 (26.4)	0.04{5.7}	2.9	ISO 4401-05-04-0-94
OCY-G03-W-X-J51 A B				0.1{14.3}	3.1	
					3.0	
OCY-G03-W-Y-J51 A B				0.1{14.3}	3.1	
					3.0	

● Handling

- ① In a 03 size application where control differential pressure is large, use of an H type makes adjustment easier.
- ② Note that a sub plate and installation bolts are not included.

Understanding Model Numbers

01, 03 size

OCY - G 03 - W - (H) Y - (K) - J51

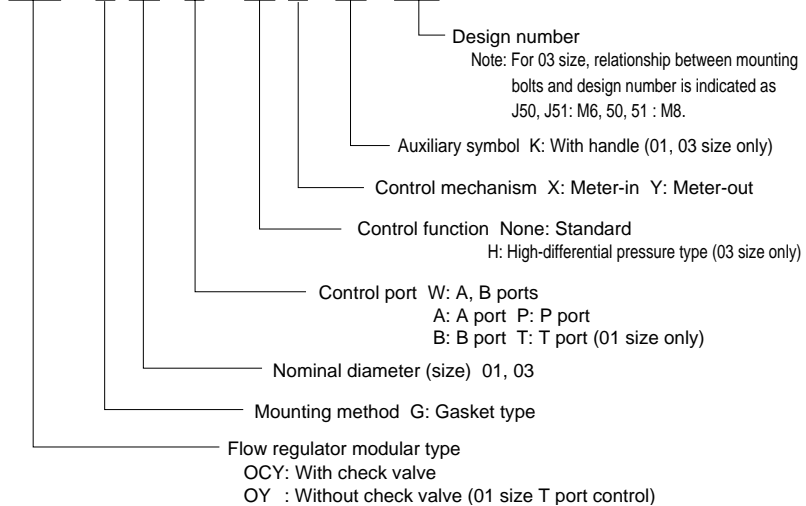

Installation Dimension Drawings

Note) The control flow rate is increased by counter clockwise (leftward) rotation of the adjusting screw.

OY-G01-T-20

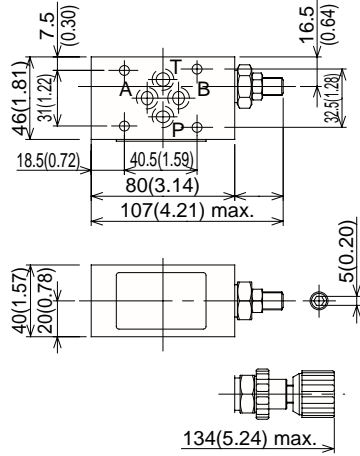

OCY-G01-P-20

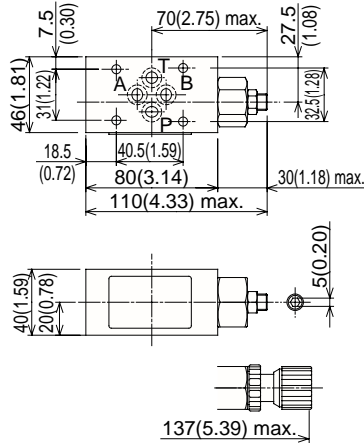

OCY-G01-W-X-20

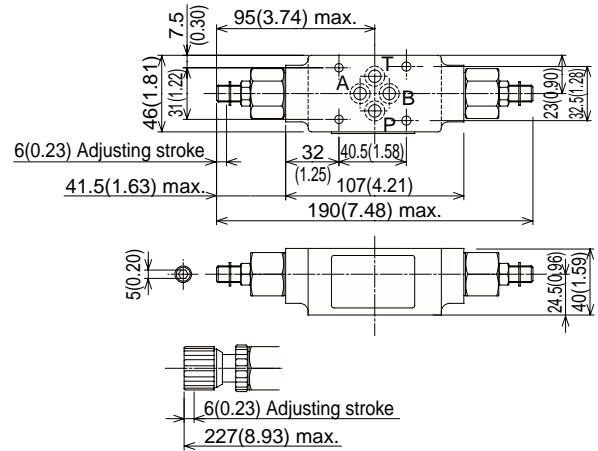

Note) Dimensions in the parentheses are for the OCY-G01-W-X-20.

OCY-G01-A-X-20

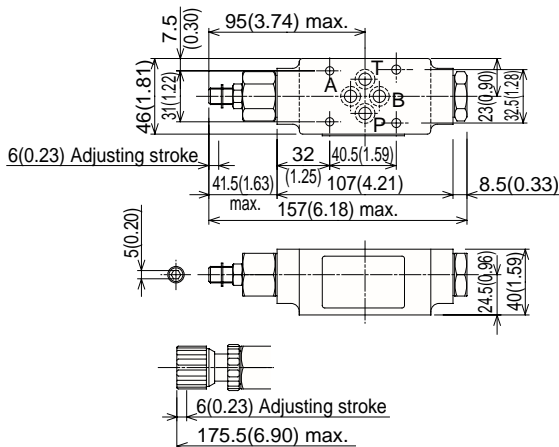

Note) Dimensions in the parentheses are for the OCY-G01-A-X-20.

OCY-G01-B-X-20

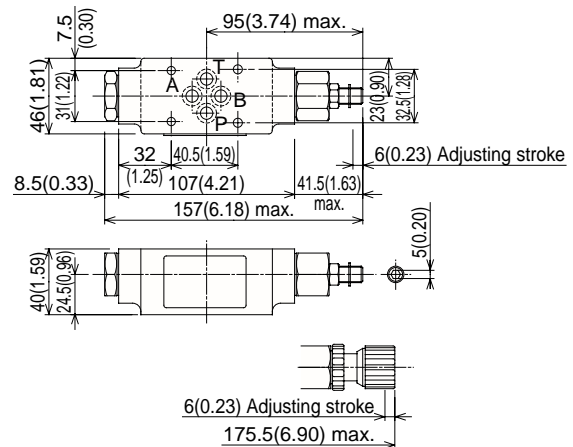

Note) Dimensions in the parentheses are for the OCY-G01-B-X-20.

OCY-G03-P-J50

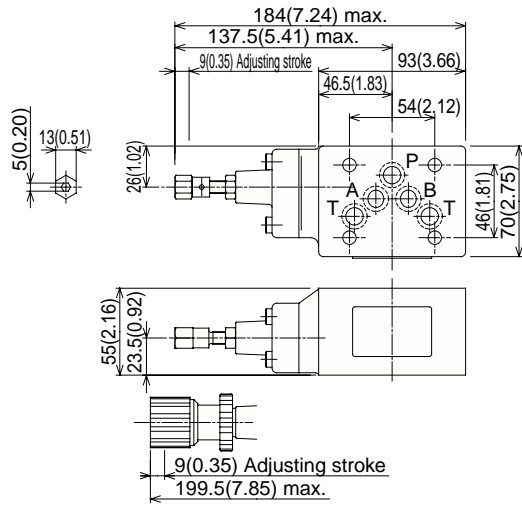

OCY-G03-W-X-J51

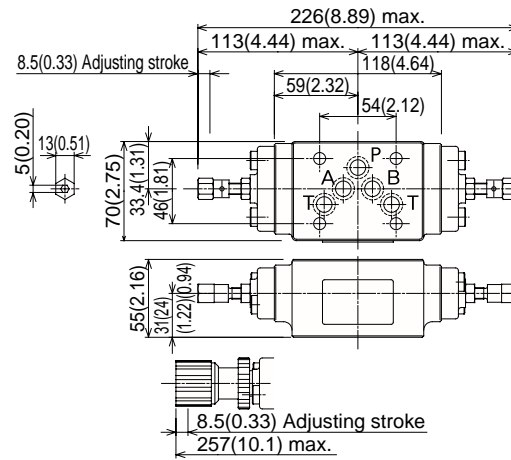

Note)
Dimensions in the parentheses are for the OCY-G03-W-X-J51.

OCY-G03-A-X-J51

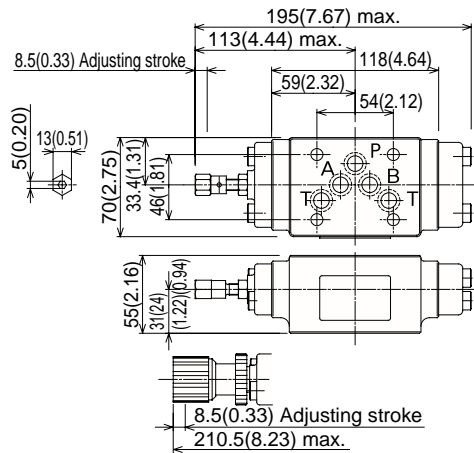

Note)
Dimensions in the parentheses are for the OCY-G03-A-X-J51.

OCY-G03-B-X-J51

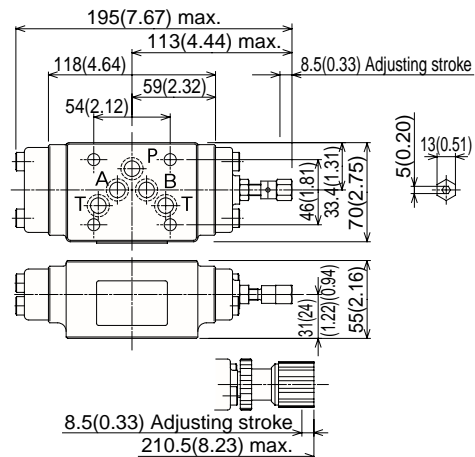

Note)
Dimensions in the parentheses are for the OCY-G03-B-X-J51.

Performance Curves

Hydraulic Operating Fluid Viscosity 32mm²/s

Pressure Loss Characteristics

OY-G01-T-20

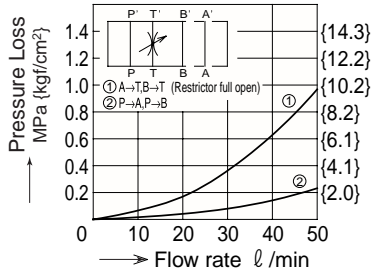

OCY-G01-P-20

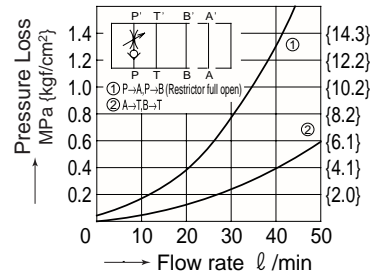

OCY-G01-W-Y-20

(OCY-G01-W-X-20)

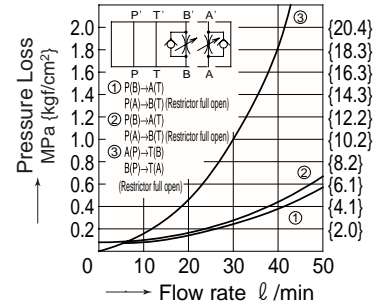

OCY-G03-P-J50

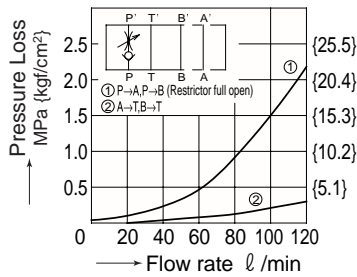

OCY-G03-W-Y-J51

(OCY-G03-W-X-J51)

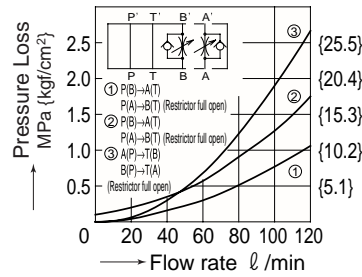

Stroke — Flow Rate Characteristics

OY-G01-T-20

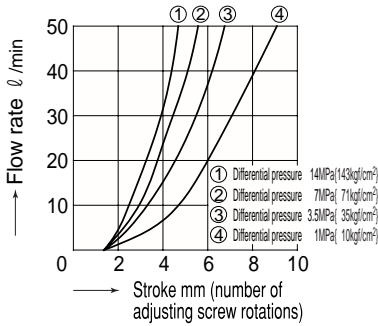

OCY-G01-P-20

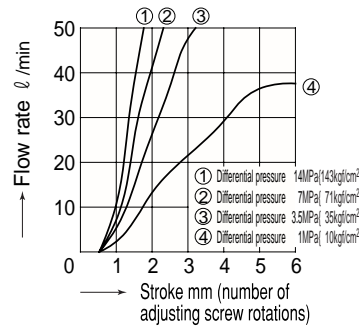

OCY-G01-*-*-20

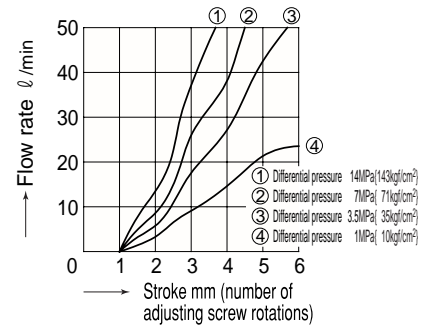

OCY-G03-P-(H)-J50

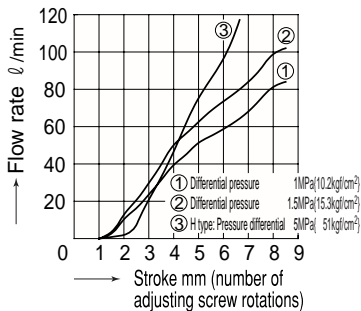

OCY-G03-W-(H)Y-J51

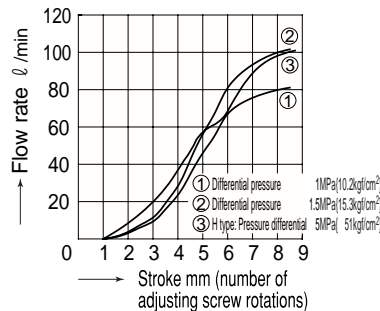

Cross-sectional Drawing

OY-G01-T-20

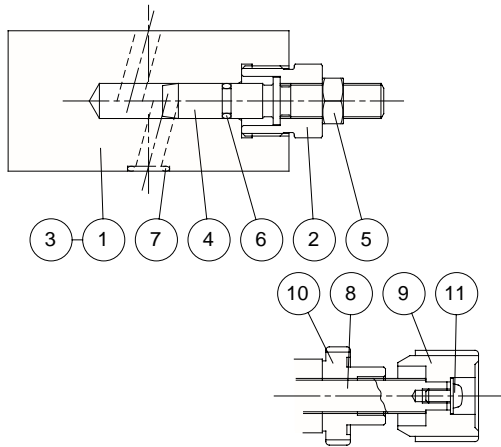

Part No.	Part Name
1	Body
2	Retainer
3	Plate
4	Screw
5	Nut
6	O-ring
7	O-ring
8	Screw
9	Knob
10	Nut
11	Screw

Seal Part List (Kit Model Number BFBS-01YT)

Part No.	Part Name	Part Number	Q'ty	
				T
6	O-ring	1B-P7	1	
7	O-ring	1B-P9	4	

Note) O-ring 1A/B-** refers to JIS B2401-1A/B.

OCY-G01-P-20

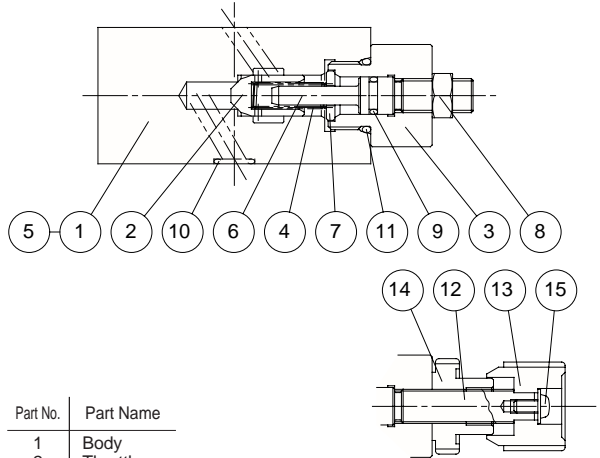

Part No.	Part Name
1	Body
2	Throttle
3	Retainer
4	Spring
5	Plate
6	Screw
7	Ring
8	Nut
9	O-ring
10	O-ring
11	O-ring
12	Screw
13	Knob
14	Nut
15	Screw

Seal Part List (Kit Model Number BFBS-01CYP)

Part No.	Part Name	Part Number	Q'ty	
				T
9	O-ring	1B-P8	1	
10	O-ring	1B-P9	4	
11	O-ring	1B-P18	1	

Note) O-ring 1A/B-** refers to JIS B2401-1A/B.

OCY-G01-A-Y-20

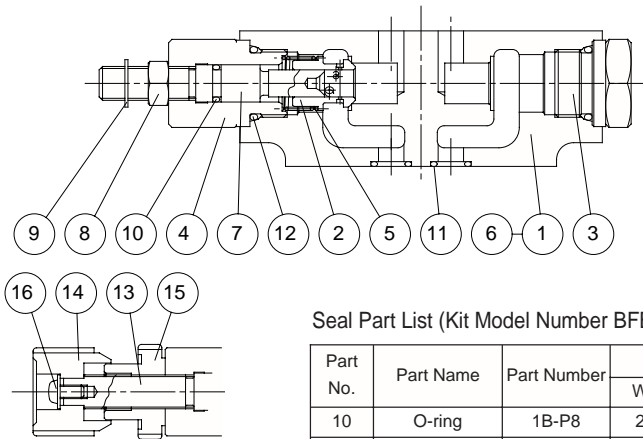

Seal Part List (Kit Model Number BFBS-01CY*)

Part No.	Part Name	Part Number	Q'ty		
			W	A	B
10	O-ring	1B-P8	2	1	1
11	O-ring	1B-P9	4	4	4
12	O-ring	1B-P18	2	2	2

Note) 1. O-ring 1A/B-** refers to JIS B2401-1A/B.
2. Specify W, A, or B for the asterisk (*) in the kit model number.

Part No.	Part Name
1	Body
2	Throttle
3	Bushing
4	Retainer
5	Spring
6	Plate
7	Screw
8	Nut
9	E-ring
10	O-ring
11	O-ring
12	O-ring
13	Screw
14	Knob
15	Nut
16	Screw

OCY-G03-P-J50

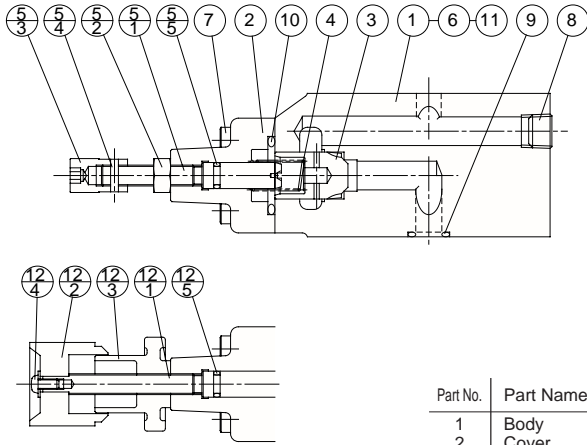

Seal Part List (Kit Model Number BFES-03CYP)

Part No.	Part Name	Part Number	Q'ty	
				P
5(12) ^{-s}	O-ring	1B-P7	1	
9	O-ring	AS568-014(Hs90)	5	
10	O-ring	1B-P24	1	

Note) O-ring 1A/B-** refers to JIS B2401-1A/B.

Part No.	Part Name
1	Body
2	Cover
3	Throttle
4	Spring
5	Screw kit
5-1	Screw
5-2	Nut
5-3	Nut
5-4	Pin
5-5	O-ring
6	Plate
7	Screw
8	Plug
9	O-ring
10	O-ring
11	Pin
12	Handle kit
12-1	Screw
12-2	Knob
12-3	Nut
12-4	Screw
12-5	O-ring

OCY-G03-A-Y-J51

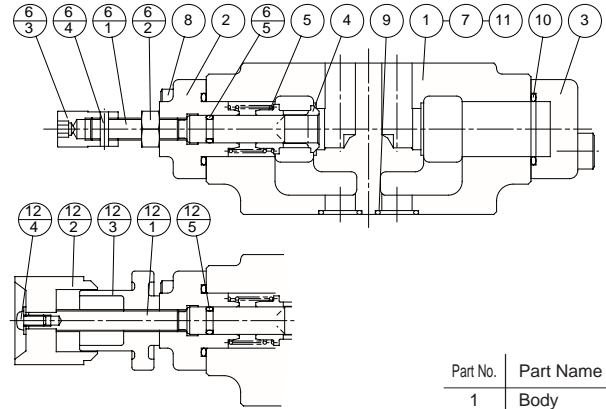

Seal Part List (Kit Model Number BFES-03CY*)

Part No.	Part Name	Part Number	Q'ty		
			W	A	B
6(12) ^{-s}	O-ring	1B-P7	2	1	1
9	O-ring	AS568-014(Hs90)	5	5	5
10	O-ring	1B-P22	2	2	2

Note) 1. O-ring 1A/B-** refers to JIS B2401-1A/B.
2. Specify W, A, or B for the asterisk (*) in the kit model number.

Part No.	Part Name
1	Body
2	Cover
3	Cover
4	Throttle
5	Spring
6	Screw kit
6-1	Screw
6-2	Nut
6-3	Nut
6-4	Pin
6-5	O-ring
7	Plate
8	Screw
9	O-ring
10	O-ring
11	Pin
12	Handle kit
12-1	Screw
12-2	Knob
12-3	Nut
12-4	Screw
12-5	O-ring

Flow Control Modular Valve (Pressure and temperature compensated)

5.3 to 15.8gpm
3000,3571psi



Features

- ① This modular valve is used to control actuator speed and for other flow control valve applications.
- ② A wide range of models are available for A and B port control, A or B port control, and P port control.
- ③ A pressure compensation mechanism ensures that the control flow rate does not change, even when there is pressure fluctuation.
- ④ The control flow rate remains stable, even when fluid temperature changes.
- ⑤ Maximum Operating Pressure : 21, 25MPa {3000, 3571psi}

Specifications

Model No.	Nominal Diameter (Size)	Maximum Working Pressure MPa{psi}	Control Flow Rate gpm	Check Valve Cracking pressure MPa{psi}	Weight kg	Gasket Surface Dimensions
OF-G01-P20-20	1/8	21{3000}	0.03 to 5.3(differential pressure: 7MPa{1000psi}) 0.08 to 5.3(differential pressure:21MPa{3000psi})	—	1.2	ISO 4401-03-02-0-94
OCF-G01-W40-X-30 A40 B40		25{3571}	0.03 to 10.6(differential pressure: 7MPa{1000psi}) 0.13 to 10.6(differential pressure:25MPa{3571psi})	0.08{11.4}	1.7	
OCF-G01-W40-Y-30 A40 B40				0.08{11.4}	1.5	
OF-G03-P60-J50	3/8	25{3571}	0.08 to 15.8(differential pressure: 7MPa{1000psi}) 0.13 to 15.8(differential pressure:25MPa{3571psi})	—	3.1	ISO 4401-05-04-0-94
OCF-G03-W60-X-J50 A60 B60				0.1{14.3}	5.0	
OCF-G03-W60-Y-J50 A60 B60				0.1{14.3}	4.6	

● Handling

- ① For flow rate control, make sure that the pressure differential between the input port and output port is at least 1MPa {146psi}. See the Flow Rate - Minimum Differential Pressure Characteristics for information about the OCF-G01 and OFF-G04 maximum control flow rate.
- ② The control flow rate is increased by counter clockwise (leftward) rotation of the flow rate control knob.
- ③ Pressure rate control knob rotation resistance will increase as the pressure increases. However, do not use a spanner or other tool that fits around the knob to turn it. Instead, insert a 5mm hex spanner into the hex hole in the center of the knob and rotate it that way.
- ④ Note that a sub plate and installation bolts are not included.
- ⑤ Flow rate fluctuation is ±5% within the temperature range of 20°C to 60°C.

Understanding Model Numbers

01, 03 size

OCF - G 03 - W 60 - Y - J50

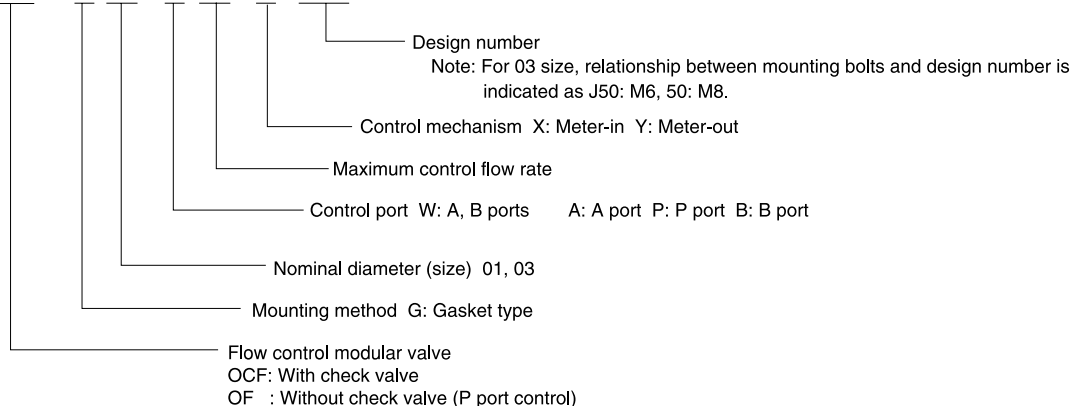

Installation Dimension Drawings

Note) The control flow rate is increased by counter clockwise (leftward) rotation of the flow rate control knob.

OF-G01-P20-20

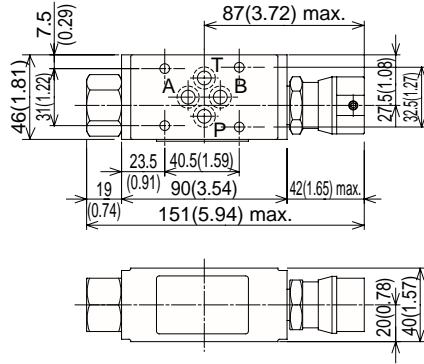

OCF-G01-W40-X/Y-30

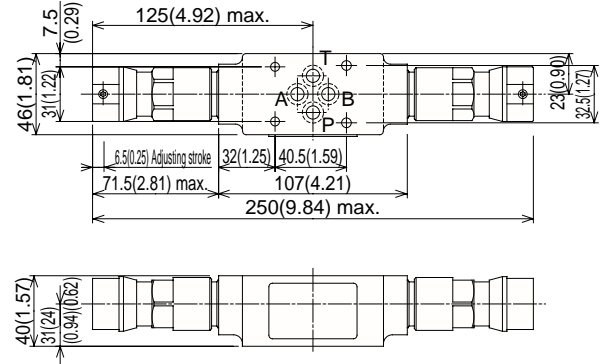

Note)
Dimensions in the parentheses are for the OCF-G01-W40-X-30.

OCF-G01-A40-X/Y-30

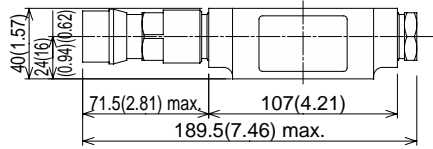

Note)
Dimensions in the parentheses are for the OCF-G01-A40-X-30.

OCF-G01-B40-X/Y-30

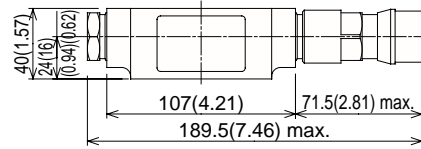

Note)
Dimensions in the parentheses are for the OCF-G01-B40-X-30.

OF-G03-P60-J50

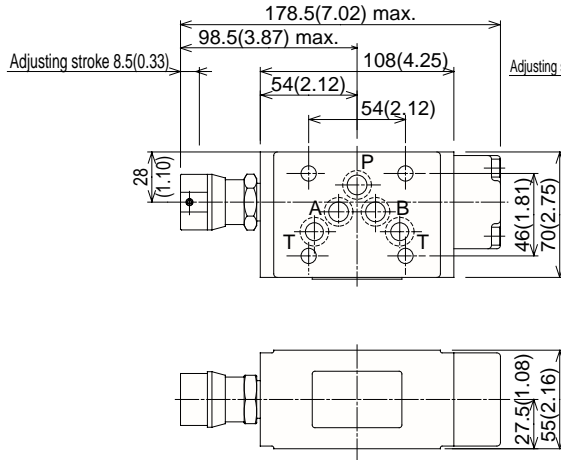

OCF-G03-W60-X/Y-J50

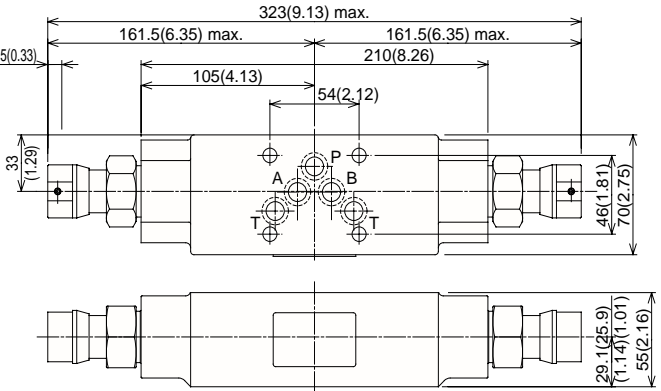

Note)
Dimensions in the parentheses are for the OCF-G03-W60-X-J50.

OCF-G03-A60-X/Y-J50

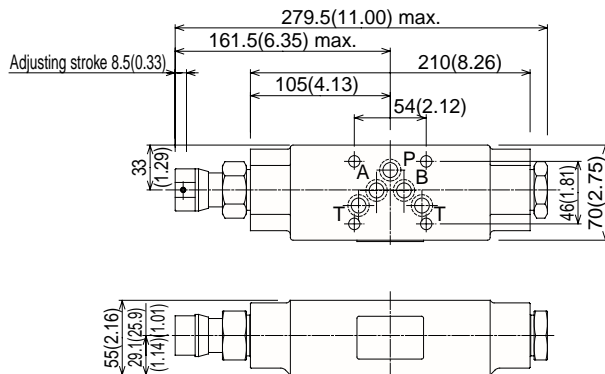

Note)
Dimensions in the parentheses are for the OCF-G03-A60-X-J50.

OCF-G03-B60-X/Y-J50

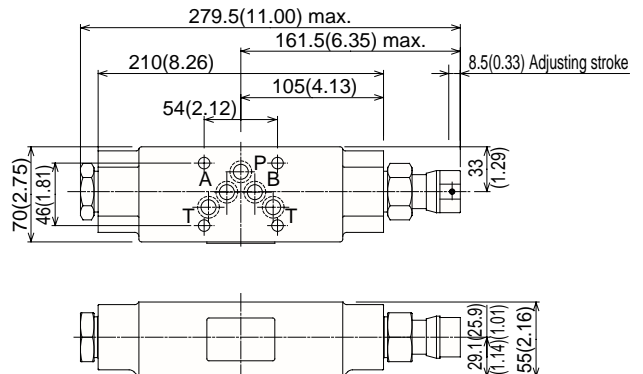

Note)
Dimensions in the parentheses are for the OCF-G03-B60-X-J50.

Performance Curves

Hydraulic Operating Fluid Viscosity 32mm²/s

Pressure Loss Characteristics

OF-G01-P20-20

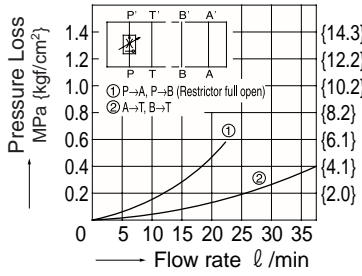

OCF-G01-A40-Y-30

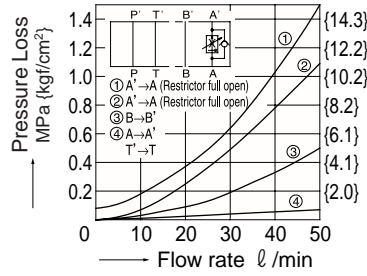

OF-G03-P60-J50

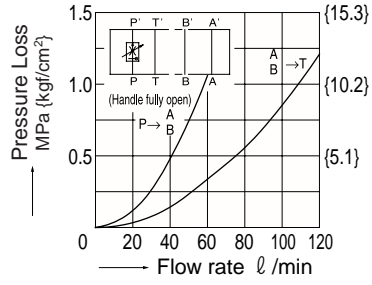

Pressure - Control Flow Rate Characteristics

OCF-G03-W60-Y-J50

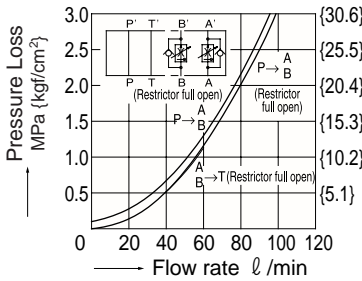

OF-G01-P20-20

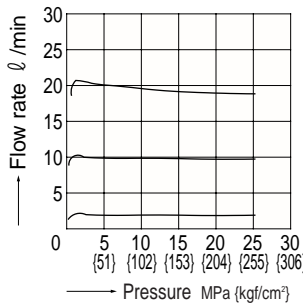

OCF-G01-*40*-30

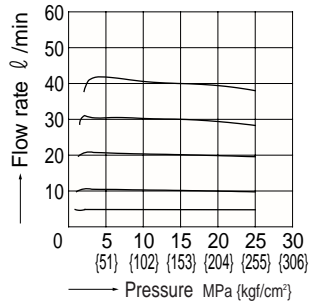

Fluid Temperature - Control Flow Rate Characteristics

OF-G03-P60-J50

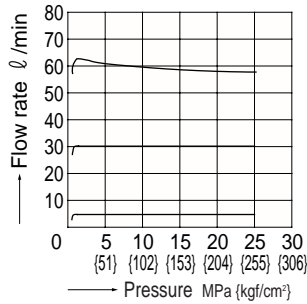

OCF-G03-W60*-J50

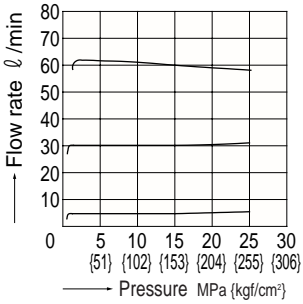

OF-G01-P20-20

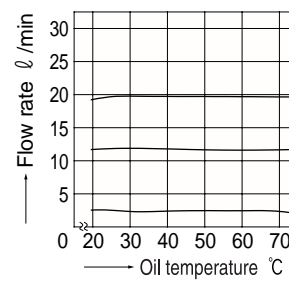

OCF-G01-*40*-30

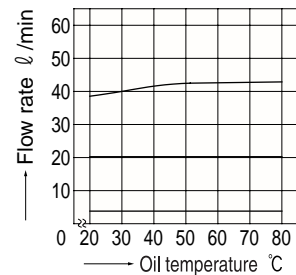

OF-G03-P60-J50

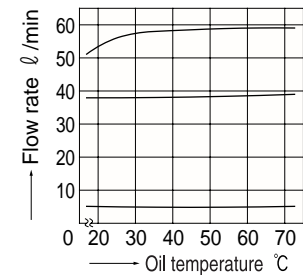

OCF-G03-W60*-J50

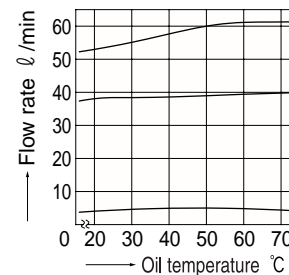

Flow Rate — Minimum Differential Pressure Characteristics
OCF-G01-*40-*-30

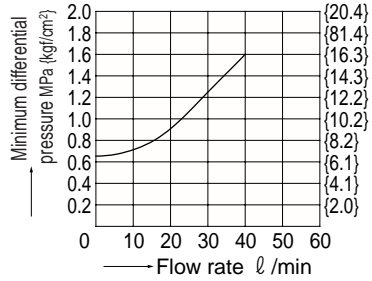

Cross-sectional Drawing

OF-G01-P20-20

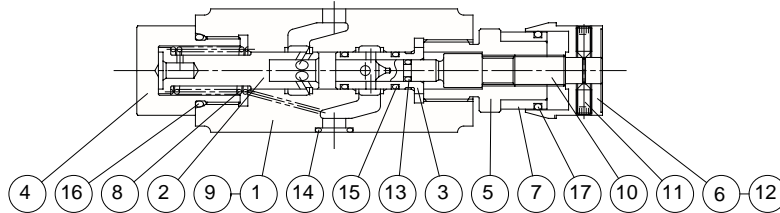

Seal Part List (Kit Model Number BFBS-01FP)

Part No.	Part Name	Part Number	Q'ty
			P
13	O-ring	1B-P4	1
14	O-ring	1B-P9	4
15	O-ring	1B-P9	2
16	O-ring	1B-P20	1
17	O-ring	1A-P22	1

Note) O-ring 1A/B-** refers to JIS B2401-1A/B.

Part No.	Part Name
1	Body
2	Piston
3	Sleeve
4	Bushing
5	Retainer
6	Knob
7	Dial
8	Spring
9	Plate
10	Screw
11	Screw
12	Screw
13	O-ring
14	O-ring
15	O-ring
16	O-ring
17	O-ring

OCF-G01-A40-Y-30

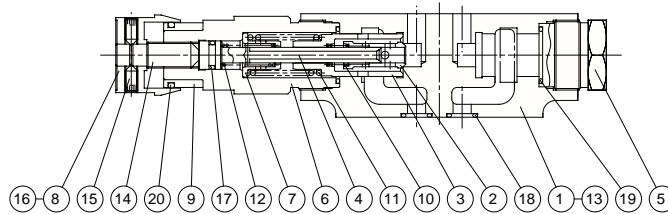

Seal Part List (Kit Model Number BFCS-01CF*)

Part No.	Part Name	Part Number	Q'ty		
			W	A	B
17	O-ring	1A-P8	2	1	1
18	O-ring	1B-P9	4	4	4
19	O-ring	AS568-018(Hs90)	2	2	2
20	O-ring	1A-P21	1	1	1

Note)

- O-ring 1A/B-** refers to JIS B2401-1A/B.
- Specify W, A, or B for the asterisk (*) in the kit model number.

Part No.	Part Name
1	Body
2	Throttle
3	Piston
4	Rod
5	Bushing
6	Retainer
7	Guide
8	Knob
9	Dial
10	Spring
11	Spring
12	Spring
13	Plate
14	Screw
15	Screw
16	Screw
17	O-ring
18	O-ring
19	O-ring
20	O-ring

OF-G03-P60-J50

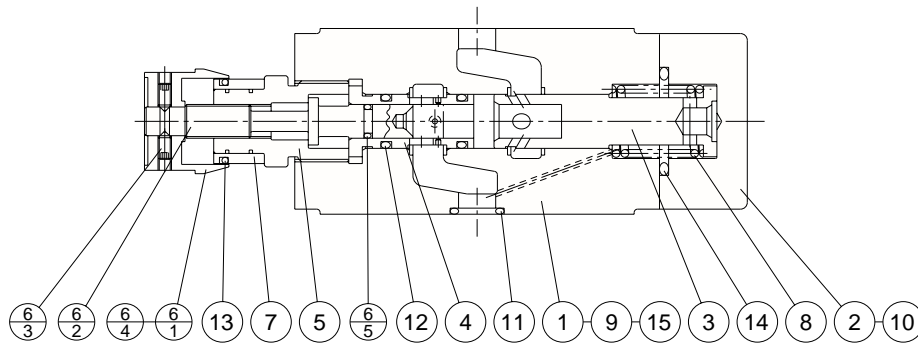

Seal Part List (Kit Model Number BFES-03FP)

Part No.	Part Name	Part Number	Q'ty	
				PC
6-5	O-ring	1A-P7	1	
11	O-ring	AS568-014(Hs90)	5	
12	O-ring	1B-P12	2	
13	O-ring	1A-P21	1	
14	O-ring	1B-P26	1	

Note) O-ring 1A/B-** refers to JIS B2401-1A/B.

Part No.	Part Name
1	Body
2	Cover
3	Piston
4	Sleeve
5	Retainer
6	Screw kit
6-1	Knob
6-2	Screw
6-3	Screw
6-4	Screw
6-5	O-ring
7	Dial
8	Spring
9	Plate
10	Screw
11	O-ring
12	O-ring
13	O-ring
14	O-ring
15	Pin

OCF-G03-A60-Y-J50

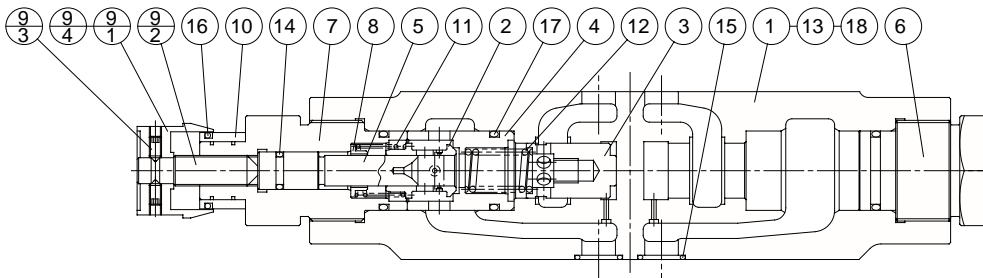

Seal Part List (Kit Model Number BFES-03CF*)

Part No.	Part Name	Part Number	Q'ty		
			W	A	B
14	O-ring	1A-P10	2	1	1
15	O-ring	AS568-014(Hs90)	5	5	5
16	O-ring	1A-P21	2	1	1
17	O-ring	1B-P22	4	3	3

Note)

1. O-ring 1A/B-** refers to JIS B2401-1A/B.
2. Specify W, A, or B for the asterisk (*) in the kit model number.

Part No.	Part Name
1	Body
2	Throttle
3	Piston
4	Sleeve
5	Rod
6	Bushing
7	Retainer
8	Guide
9	Screw kit
9-1	Knob
9-2	Screw
9-3	Screw
9-4	Screw
10	Dial
11	Spring
12	Spring
13	Plate
14	O-ring
15	O-ring
16	O-ring
17	O-ring
18	Pin



Gauge Modular Block

13.2 to 26.4gpm
3571psi

Features

- ① This modular block makes it possible to attach a pressure gauge to the P and T ports or the A and B ports.
- ② Connection to the ports is extremely simple.

Specifications

Model No.	Nominal Diameter (Size)	Maximum Working Pressure MPa{psi}	Maximum Flow Rate ℓ /min (gpm)	Weight kg	Gasket Surface Dimensions
OK-G01-P-E20 OK-G01-T-E20	1/8	25{3571}	50 (13.2)	0.6	ISO 4401-03-02-0-94
OK-G01-W-E20				0.6	
OK-G01-P-H-E20 OK-G01-T-H-E20				1.0	
OK-G01-W-H-E20				1.0	
OK-G03-E50	3/8	25{3571}	100(26.4)	2.3	ISO 4401-05-04-0-94

Understanding Model Numbers

OK - G 01 - P - E20

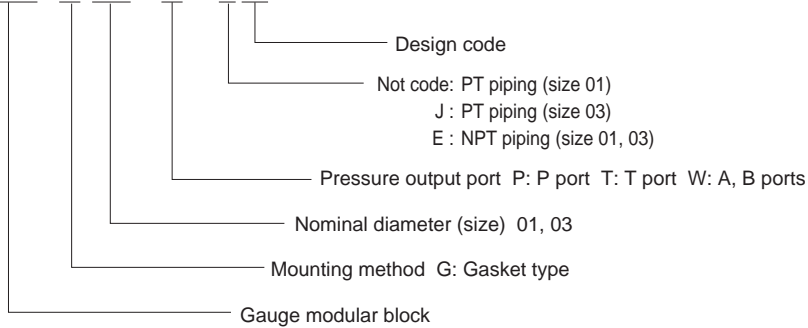

● Handling

- ① When installing the OK-G01-P- (H)-20, OK-G01-T-(H)-20, or OK-G01-W-(H)-20, make sure the model number printing is oriented so it can be read correctly from the P port side.
- ② Note that a sub plate and installation bolts are not included.

Installation Dimension Drawings

OK-G01-P-E20

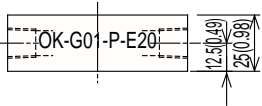
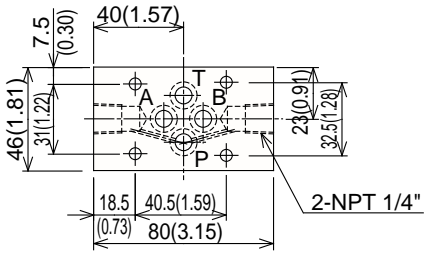

OK-G01-T-E20

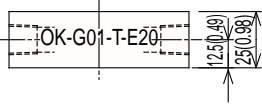
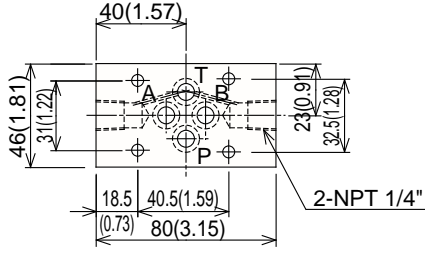

OK-G01-W-E20

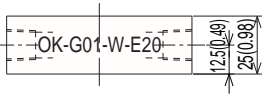
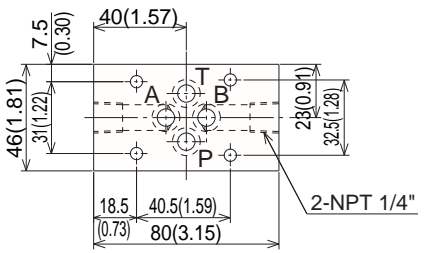

OK-G01-P-H-E20

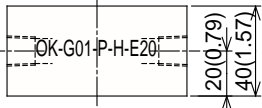
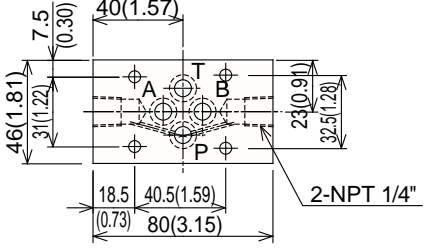

OK-G01-T-H-E20

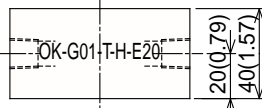
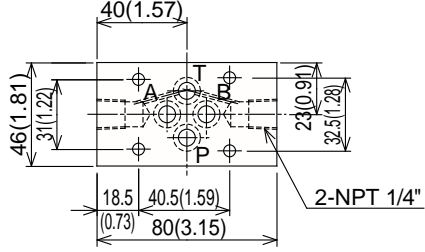

OK-G01-W-H-E20

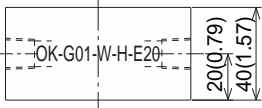
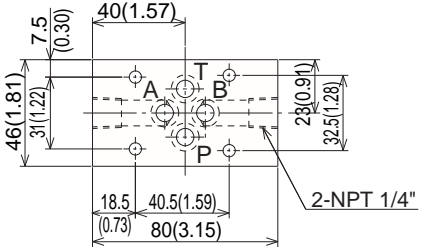

OK-G03-E50

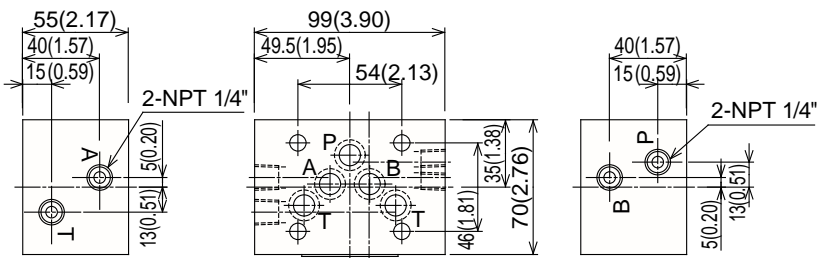



Check Modular Valve

13.2 to 26.4gpm
3571psi

Features

- ① This modular valve is a check valve that prevents reverse-flow.
- ② The 01, 03 sizes include types that can also be used as suction and differential circuits.
- ③ Maximum Operating Pressure: 25MPa {3571psi}

Specifications

Model No.	Nominal Diameter (Size)	Maximum Working Pressure MPa(psi)	Maximum Flow Rate ℓ /min(gpm)	Cracking pressure MPa(psi)	Weight kg	Gasket Surface Dimensions
OC-G01-P1-20 P2 P3	1/8	25{3571}	50 (13.2)	0.04{5.7}	1.0	ISO 4401-03-02-0-94
OC-G01-T1-20 T2 T3				0.35{50}		
OC-G01-A1-21 A2 A3				0.50{71}		
OC-G01-AP1-20 AP2 AP3				0.04{5.7}		
OCV-G01-W-20				0.35{50}		
OC-G03-P1-J50 P2 P3	3/8	25{3571}	100 (26.4)	0.04{5.7}	2.7	ISO 4401-05-04-0-94
OC-G03-T1-J50 T2 T3				0.35{50}		
OC-G03-A1-J50 A2 A3				0.50{71}		
OC-G03-AP1-J50 AP2 AP3				0.04{5.7}		
OCV-G03-W-J50				0.35{50}		
				0.015{2.14}	3.5	

● Handling

- ① Differential circuit can be easily configured at P → B by attaching OC-G**-A* above the OC-G**-AP* on the sub-plate. (See the figure to the right.)
- ② Note that a sub plate and installation bolts are not included.

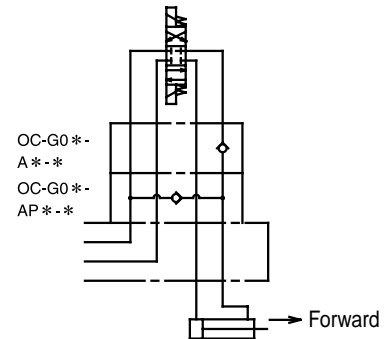

Understanding Model Numbers

01, 03 size

OC (OCV) – G 03 – P 1 – J50

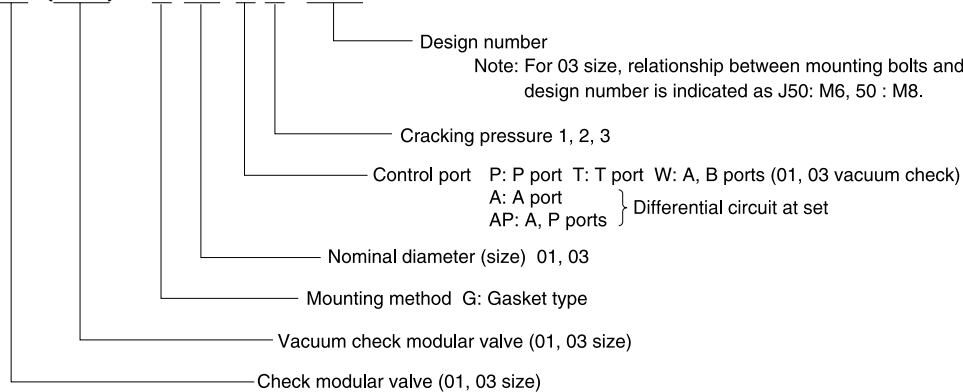

Installation Dimension Drawings

OC-G01-T*-20
P
AP

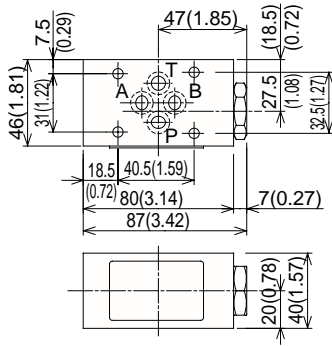

OC-G01-A*-21

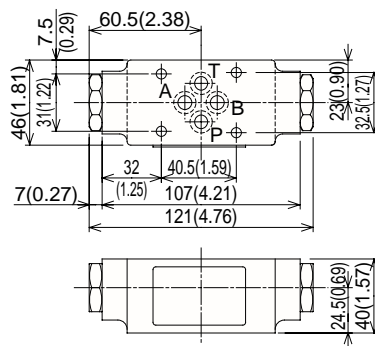

OCV-G01-W-20

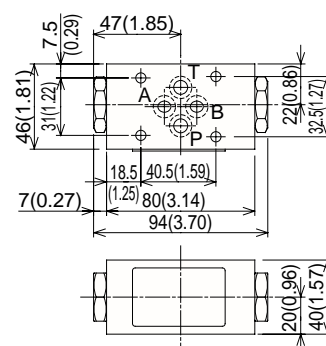

Note) Dimensions in the parentheses are for the OC-G01-T*-20.

OC-G03-P
AP*-J50

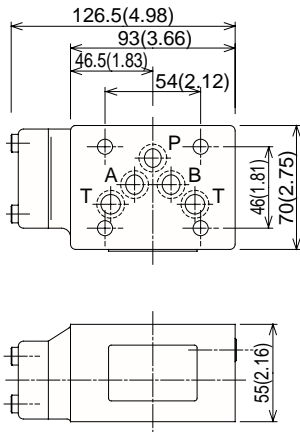

OC-G03-A*-J50

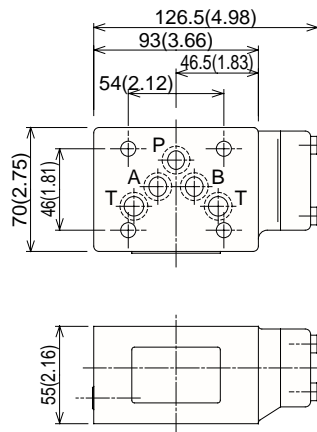

OC-G03-T*-J50

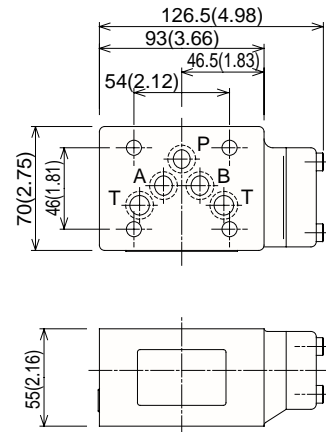

OCV-G03-W-J50

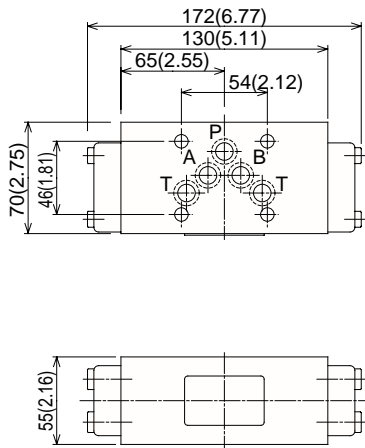

Performance Curves

Hydraulic Operating Fluid Viscosity 32mm²/s

Pressure Loss Characteristics

OC-G01-P*-20

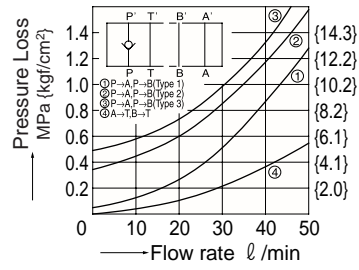

OCV-G01-W-20

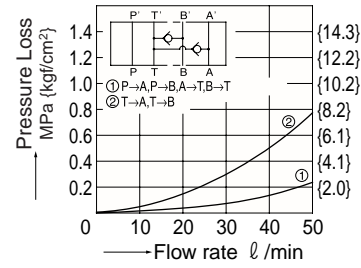

OC-G03-P*-J50

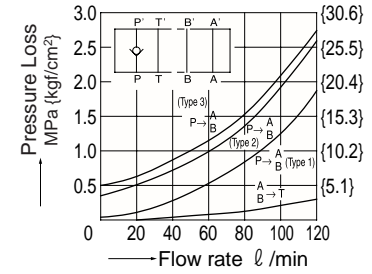

OC-G03-AP*-J50

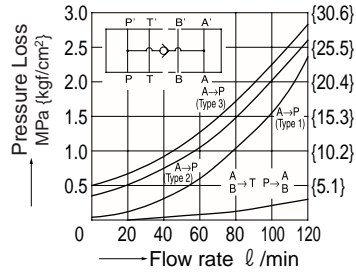

OC-G03-A*-J50

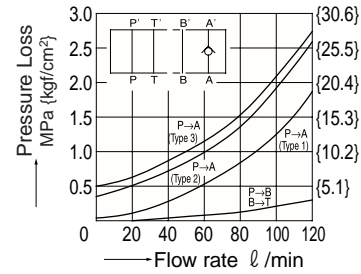

OC-G03-T*-J50

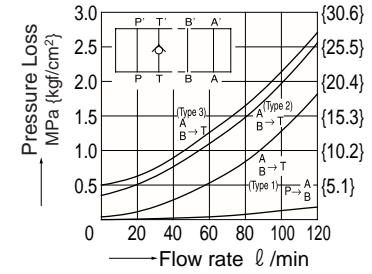

OCV-G03-W-J50

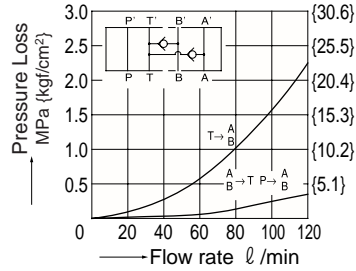

Cross-sectional Drawing

P
OC-G01-T*-20
AP

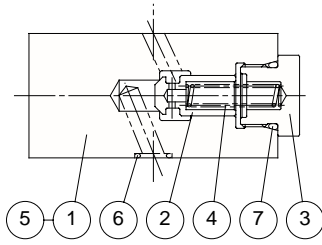

Part No.	Part Name
1	Body
2	Poppet
3	Guide
4	Spring
5	Plate
6	O-ring
7	O-ring

Seal Part List (Kit Model Number BRBS-01C*)

Part No.	Part Name	Part Number	Q'ty		
			P	T	AP
6	O-ring	1B-P9	4	4	4
7	O-ring	1B-P18	1	1	1

Note)

1. O-ring 1A/B-** refers to JIS B2401-1A/B.
2. Specify P, T, or AP for the asterisk (*) in the kit model number.

OCV-G01-W-20

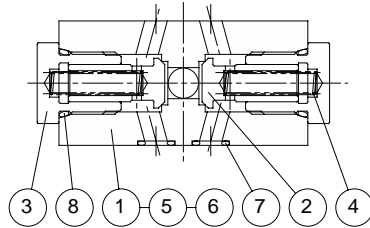

Part No.	Part Name
1	Body
2	Poppet
3	Guide
4	Spring
5	Plate
6	Plug
7	O-ring
8	O-ring

OC-G01-A*-21

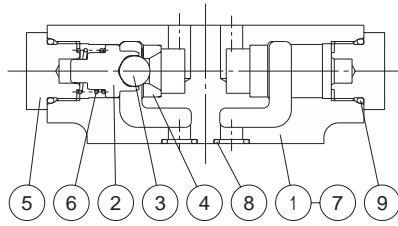

Part No.	Part Name
1	Body
2	Poppet
3	Ball
4	Seat
5	Guide
6	Spring
7	Plate
8	O-ring
9	O-ring

Seal Part List (Kit Model Number BDBS-01CA)

Part No.	Part Name	Part Number	Q'ty
			A
8	O-ring	1B-P9	4
9	O-ring	1B-P18	2

Note)

1. O-ring 1A/B-** refers to JIS B2401-1A/B.

Seal Part List (Kit Model Number BDBS-01CVW)

Part No.	Part Name	Part Number	Q'ty
			W
7	O-ring	1B-P9	4
8	O-ring	1B-P18	2

Note)

1. O-ring 1A/B-** refers to JIS B2401-1A/B.

OC-G03-P*-J50

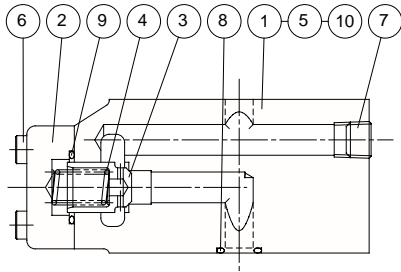

Part No.	Part Name
1	Body
2	Cover
3	Poppet
4	Spring
5	Plate
6	Screw
7	Plug
8	O-ring
9	O-ring
10	Pin

OC-G03-T*-J50

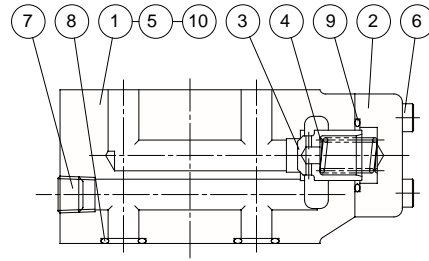

Part No.	Part Name
1	Body
2	Cover
3	Poppet
4	Spring
5	Plate
6	Screw
7	Plug
8	O-ring
9	O-ring
10	Pin

OC-G03-A*-J50

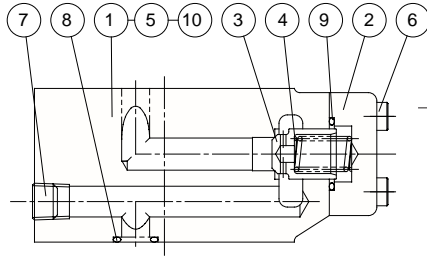

Part No.	Part Name
1	Body
2	Cover
3	Poppet
4	Spring
5	Plate
6	Screw
7	Plug
8	O-ring
9	O-ring
10	Pin

OC-G03-AP*-J50

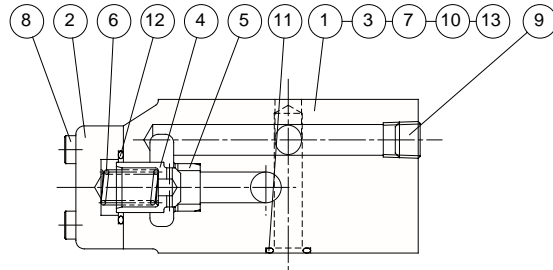

Part No.	Part Name
1	Body
2	Cover
3	Plug
4	Poppet
5	Seat
6	Spring
7	Plate
8	Screw
9	Plug
10	O-ring
11	O-ring
12	O-ring
13	Pin

Seal Part List (Kit Model Number BDES-03C*)

Part No.	Part Name	Part Number	Q'ty		
			P	T	A
8	O-ring	AS568-014(Hs90)	5	5	5
9	O-ring	1B-P22	1	1	1

Note)

- O-ring 1A/B-** refers to JIS B2401-1A/B.
- Specify P, T, or A for the asterisk (*) in the kit model number.

Seal Part List (Kit Model Number BDES-03CAP)

Part No.	Part Name	Part Number	Q'ty
			AP
10	O-ring	1B-P11	1
11	O-ring	AS568-014(Hs90)	5
12	O-ring	1B-P22	1

Note)

- O-ring 1A/B-** refers to JIS B2401-1A/B.

OCV-G03-W-J50

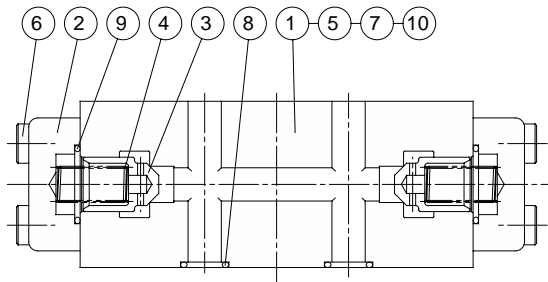

Seal Part List (Kit Model Number BDES-03CVW)

Part No.	Part Name	Part Number	Q'ty
			W
7	O-ring	1B-P10A	2
8	O-ring	AS568-014(Hs90)	5
9	O-ring	1B-P22	2

Part No.	Part Name	Part No.	Part Name	Part No.	Part Name
1	Body	5	Plate	9	O-ring
2	Cover	6	Screw	10	Pin
3	Poppet	7	O-ring		
4	Spring	8	O-ring		

Pilot Operated Check Modular Valve

13.2 to 26.4gpm
3571psi



Features

- ① This modular valve is used to prevent actuator self-running and to maintain actuator position.
- ② Maximum Operating Pressure: 25MPa {3571psi}

Specifications

Model No.	Nominal Diameter (Size)	Maximum Working Pressure MPa{psi}	Maximum Flow Rate ℓ/min{gpm}	Cracking pressure MPa{psi}	Area Ratio			Weight kg	Gasket Surface Dimensions	
					Pilot Piston	Check Valve Seat	Needle Valve Seat			
OCP-G01-W1-21 W2	1/8	25{3571}	50 (13.2)	0.2{29} 0.5{71}	1	0.37	—	1.2	ISO 4401-03-02-0-94	
OCP-G01-A1-21 A2				0.2{29} 0.5{71}						
OCP-G01-B1-21 B2				0.2{29} 0.5{71}						
OCP-G01-W1-F-21 W2				1	0.51	0.06	1.2			
OCP-G01-A1-F-21 A2										0.2{29} 0.5{71}
OCP-G01-B1-F-21 B2										0.2{29} 0.5{71}
OCP-G03-W1-J50 W2	3/8	25{3571}	100 (26.4)	0.2{29} 0.5{71}	1	0.49		0.07	3.6	ISO 4401-05-04-0-94
OCP-G03-A1-J50 A2				0.2{29} 0.5{71}						
OCP-G03-B1-J50 B2				0.2{29} 0.5{71}						
OCP-G03-W1-D-J50 W2				1	0.49	—	3.6			
OCP-G03-A1-D-J50 A2								0.2{29} 0.5{71}		
OCP-G03-B1-D-J50 B2								0.2{29} 0.5{71}		

● Handling

- ① Note that when the 01 size has the auxiliary symbol "F," tank port back pressure can cause the small valve to open, making it impossible to maintain pressure.
- ② If tank port back pressure causes the small valve to open and make it impossible to maintain pressure with the 03 size, use a direct type with auxiliary symbol "D."
- ③ Minimum pilot pressure fluctuates with the input side pressure during reverse flow. Operate the valve so pressure is at least twice as high as the required pressure obtained using the minimum pilot pressure characteristics graph.
- ④ Note that a sub plate and installation bolts are not included.

Understanding Model Numbers

01, 03 size

OCP - G 03 - W 1 - (D) - J50

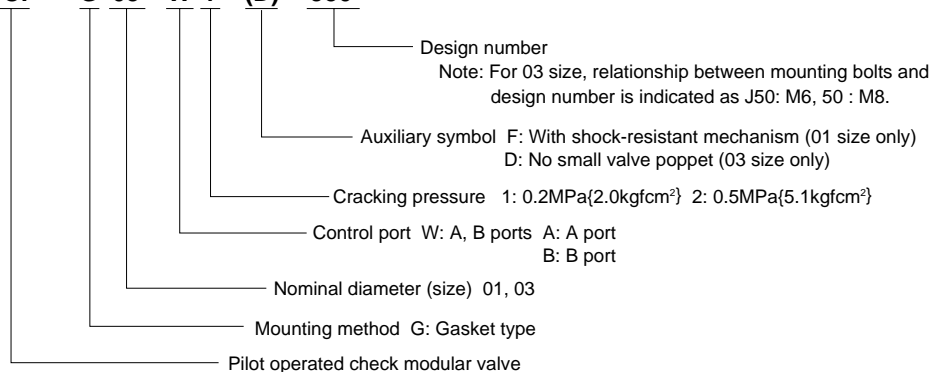

Installation Dimension Drawings

OCP-G01-**-F)-21

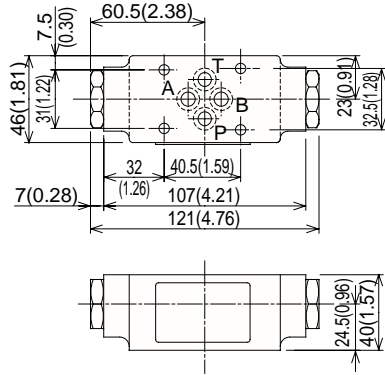

OCP-G03-**-D)-J50

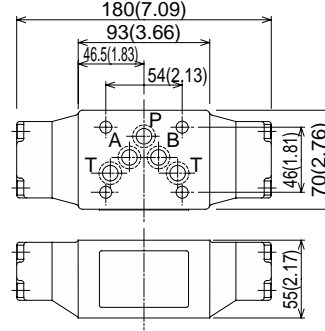

Performance Curves

Hydraulic Operating Fluid Viscosity 32mm²/s

Pressure Loss Characteristics

OCP-G01-W*-F)-21

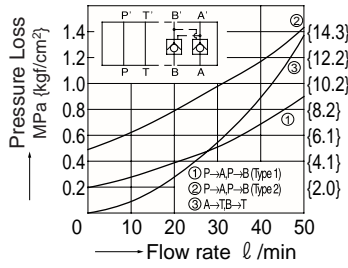

OCP-G01-W*-F)-21

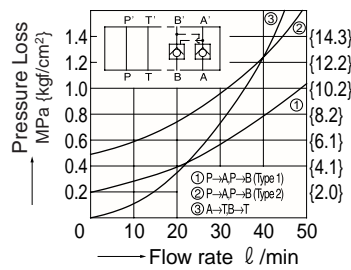

OCP-G03-W*-(D)-J50

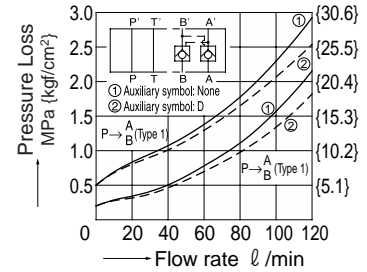

Pressure Loss Characteristics (Reverse Free Flow)

OCP-G03-W*-(D)-J50

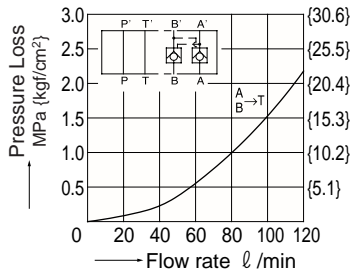

Minimum Pilot Pressure Characteristics

OCP-G01-**-F)-21

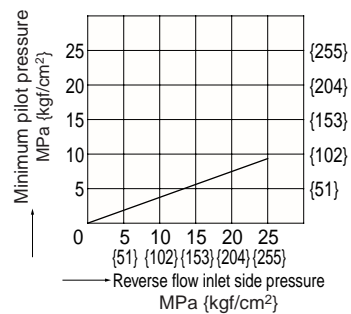

OCP-G01-**-F)-21

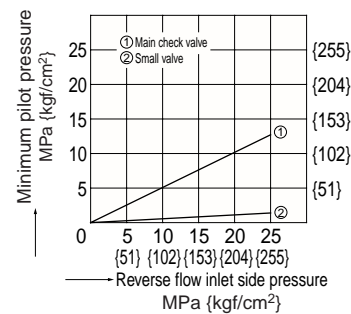

OCP-G03-W*-(D)-J50

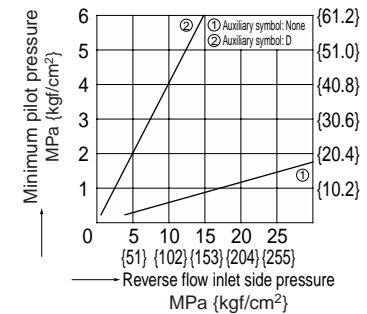

Cross-sectional Drawing

OCP-G01-A*-21

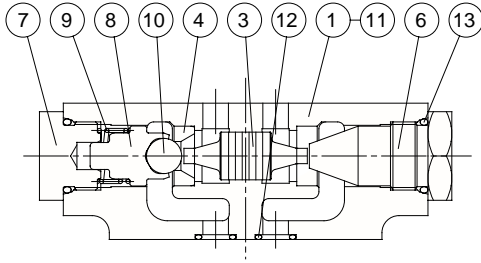

OCP-G01-A*-F-21

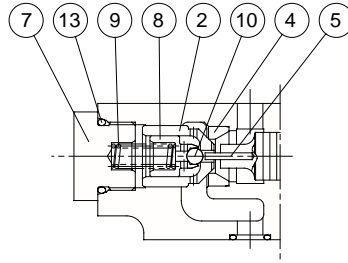

Part No.	Part Name
1	Body
2	Poppet
3	Piston
4	Seat
5	Rod
6	Bushing
7	Guide
8	Guide
9	Spring
10	Ball
11	Plate
12	O-ring
13	O-ring

Seal Part List (Kit Model Number BDBS-01CP)

Part No.	Part Name	Part Number	Q'ty		
			W	A	B
12	O-ring	1B-P9	4	4	4
13	O-ring	1B-P18	2	2	2

Note) 1. O-ring 1A/B-** refers to JIS B2401-1A/B.
2. Specify W, A, or B for the asterisk (*) in the kit model number.

OCP-G03-A*-J50

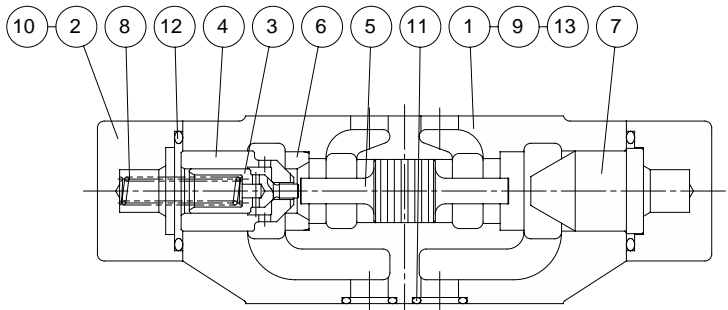

Part No.	Part Name
1	Body
2	Cover
3	Poppet
4	Poppet
5	Piston
6	Seat
7	Bushing
8	Spring
9	Plate
10	Screw
11	O-ring
12	O-ring
13	Pin

OCP-G03-**-D-J50

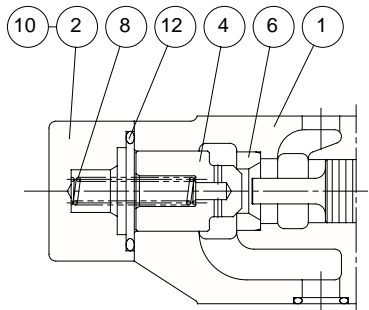

Seal Part List (Kit Model Number BDES-03CP*)

Part No.	Part Name	Part Number	Q'ty		
			W	A	B
11	O-ring	AS568-014(Hs90)	5	5	5
12	O-ring	1B-P29	2	2	2

Note) 1. O-ring 1A/B-** refers to JIS B2401-1A/B.
2. Specify W, A, or B for the asterisk (*) in the kit model number.

Relief Modular Valve

13.2 to 21.2gpm
3571psi



Features

- ① This modular relief valve provides maximum pressure control for a hydraulic circuit.
- ② Wide ranging applicability Maximum Operating Pressure: 25, 35MPa {255, 357kgf/cm²} Pressure Adjustment Range: 0.8 to 25, 35MPa {8.2 to 255, 357kgf/cm²}
- ③ Shockless unload, 2-pressure control, and other configurations are possible by switching the solenoid valve. Contact your agent for details.

Specifications

Model No.	Nominal Diameter (Size)	Maximum Working Pressure MPa(psi)	Maximum Flow Rate ℓ/min(gpm)	Pressure Adjustment Range MPa(psi)	Weight kg	Gasket Surface Dimensions
OR-G01-P1-20 P3	1/8	25 {3571}	50 (13.2)	* to 7{ * to 1000} 3.5 to 25{500 to 3571}	1.5	ISO 4401-03-02-0-94
OR-G01-W1-20 W3				* to 7{ * to 1000} 3.5 to 25{500 to 3571}	2.3	
OR-G01-A1-21 A3				* to 7{ * to 1000} 3.5 to 25{500 to 3571}	1.6	
OR-G01-B1-21 B3				* to 7{ * to 1000} 3.5 to 25{500 to 3571}	1.6	
OR-G03-P1-(V)-J50 P3	3/8	25 {3571}	80 (21.2)	* to 7{ * to 1000} 3.5 to 25{500 to 3571}	3.1	ISO 4401-05-04-0-94
OR-G03-W1-J50 W3				* to 7{ * to 1000} 3.5 to 25{500 to 3571}	3.9	
OR-G03-A1-E50 A3				* to 7{ * to 1000} 3.5 to 25{500 to 3571}	3.1	
OR-G03-B1-E50 B3				* to 7{ * to 1000} 3.5 to 25{500 to 3571}	3.1	

Note) See the Flow Rate - Low Pressure characteristics on page M-12 for information about items marked with an asterisk.*

● Handling

- ① When using a remote control valve in a vent circuit, certain vent circuit pipe capacities can cause vibration. Because of this, thick steel pipe with an inside diameter of φ4mm that is no longer than three meters is recommended. Vent piping cannot be used with the 01 size. If a vent port is required for the 03 size, add the auxiliary code "V".
- ② For use as a safety valve, use a pressure override that is higher than the required circuit pressure.
- ③ Make sure that tank port back pressure is no greater than 0.2MPa {29psi},
- ④ A small control flow rate can cause pressure instability. Use a control flow rate that is in accordance with the values shown below.
01 size: At least 1.3gpm
03 size: At least 2.1gpm
- ⑤ For applications that require a flow rate that is less than the minimum flow rate, use an ORD-G** direct type relieve modular valve.
- ⑥ Note that a sub plate and installation bolts are not included.
- ⑦ Connect OR-G03-W*-(J) 50 to the two T-ports on the tanks.

Understanding Model Numbers

01: 03 size

OR-G 03 - P 1 - (K) - E 50

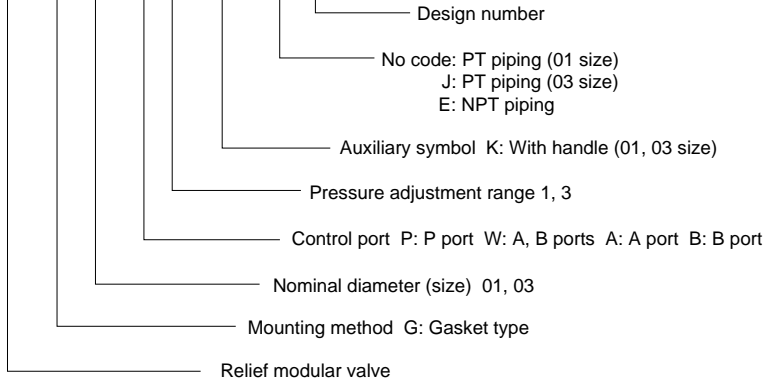

Installation Dimension Drawings

mm(inch)

Note) Pressure is increased by clockwise (rightward) rotation of the adjusting screw (bolt), and decreased by counterclockwise (leftward) rotation.

OR-G01-P*-20

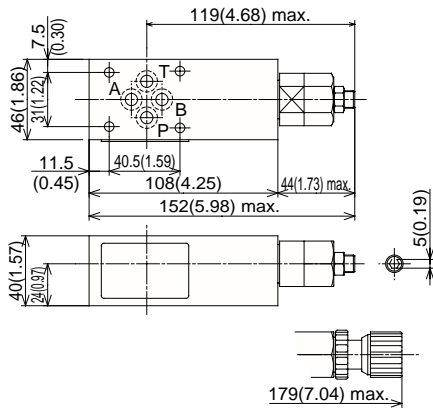

OR-G01-W*-20

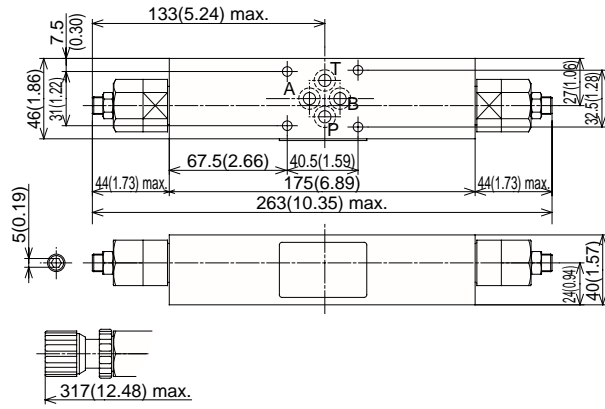

OR-G01-A*-21

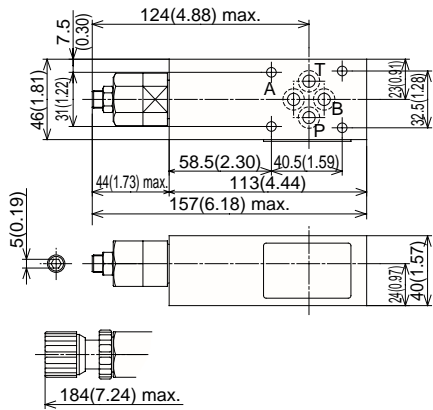

OR-G01-B*-21

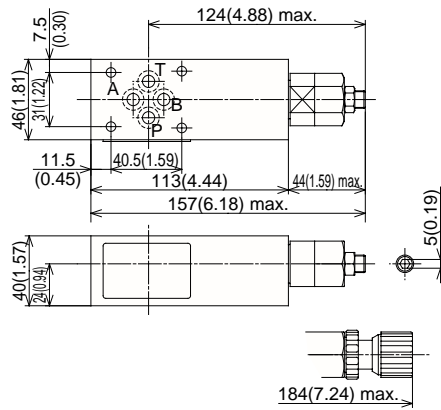

OR-G03-P*-(V)-J50

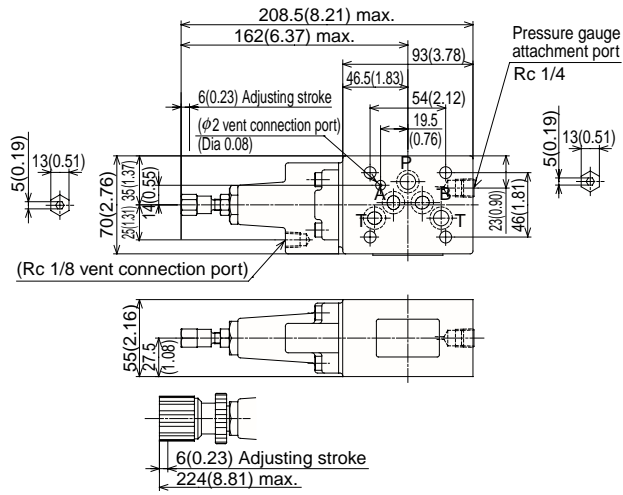

OR-G03-W*-(V)-J50

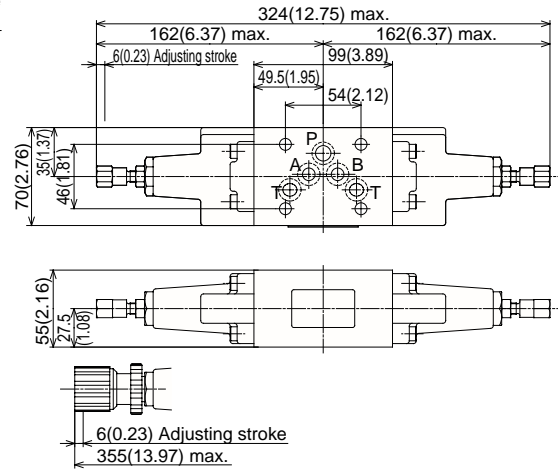

Note) Dimensions in parentheses show dimensions with vent port installed (V type)

OR-G03-A*-E50

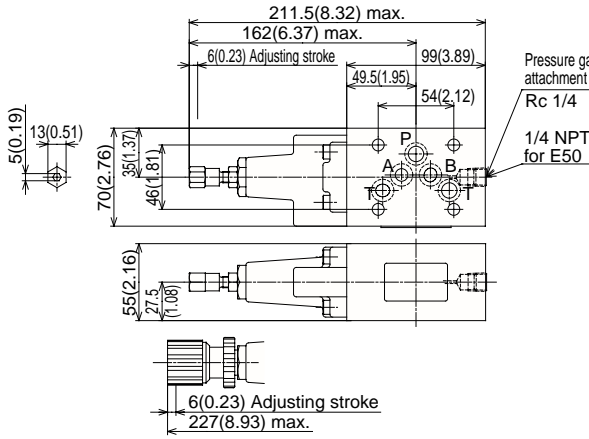

OR-G03-B*-E50

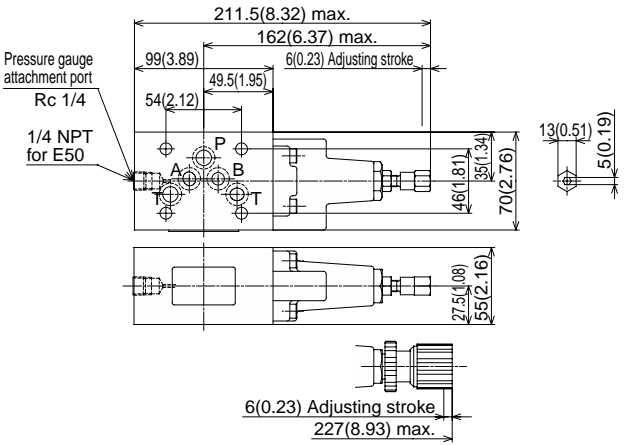

Performance Curves

Differential Hydraulic Fluid Viscosity 32mm²/s

Flow Rate – Minimum Pressure Characteristics

OR-G01-*1-20(21)

OR-G03-P1-E50

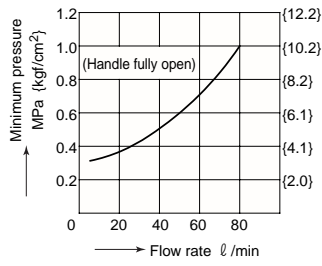
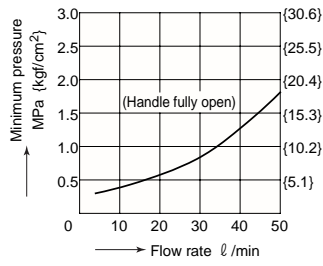

Pressure – Flow Rate Characteristics

OR-G01-**-20(21)

OR-G03-P*-E50

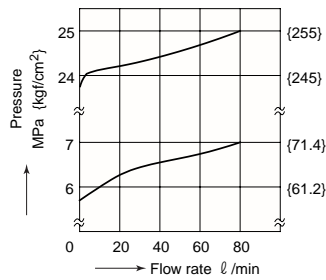
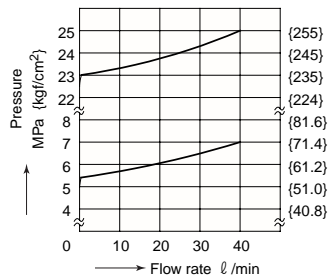

Number of Adjusting Screw Rotations – Pressure Characteristics

OR-G01-P*-20

OR-G03-P*-(E)50

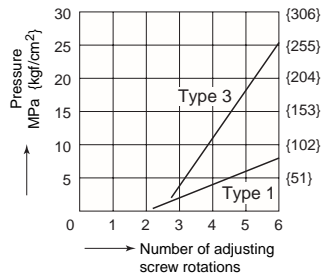
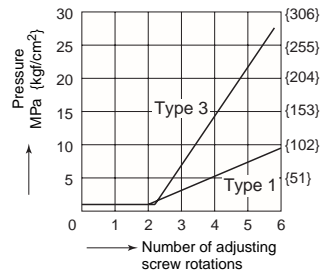

Cross-sectional Drawing

OR-G01-P*-20

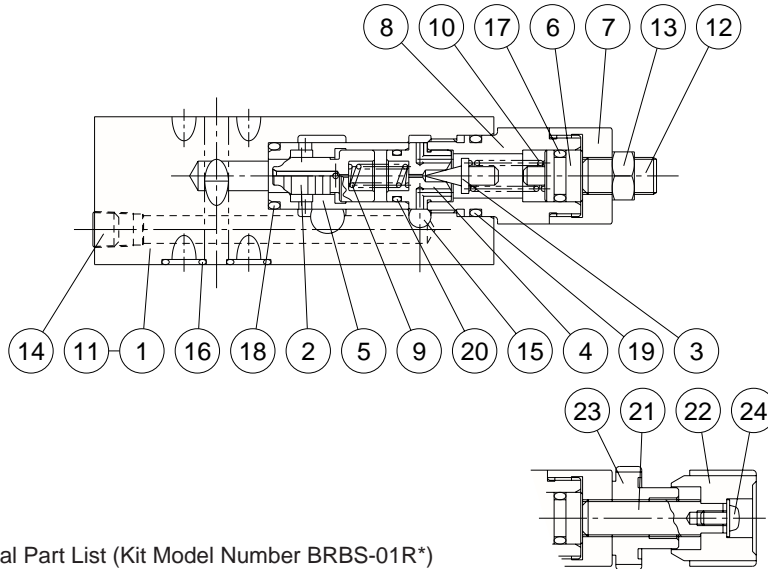

Part No.	Part Name
1	Body
2	Spool
3	Poppet
4	Seat
5	Sleeve
6	Plunger
7	Bushing
8	Retainer
9	Spring
10	Spring
11	Plate
12	Screw
13	Nut
14	Plug
15	Plug
16	O-ring
17	O-ring
18	O-ring
19	O-ring
20	O-ring
21	Screw
22	Knob
23	Nut
24	Screw

Seal Part List (Kit Model Number BRBS-01R*)

Part No.	Part Name	Part Number	Q'ty			
			P	W	A	B
16	O-ring	1B-P9	4	4	4	4
17	O-ring	1A-P10A	1	2	1	1
18	O-ring	1B-P14	1	2	1	1
19	O-ring	1B-P18	1	2	1	1
20	O-ring	AS568-013(Hs90)	1	1	1	1

Note) 1. O-ring 1A/B-** refers to JIS B2401-1A/B.
2. Specify P, W, A, or B for the asterisk (*) in the kit model number.

OR-G03-P*-V-J50

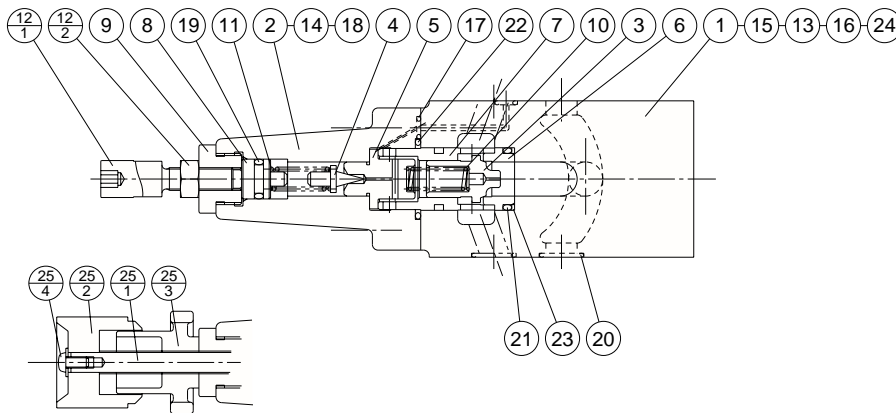

Part No.	Part Name
1	Body
2	Cover
3	Spool
4	Poppet
5	Seat
6	Seat
7	Sleeve
8	Plunger
9	Retainer
10	Spring
11	Spring
12	Screw kit
12 ₁	Screw
12 ₂	Nut
13	Plate
14	Screw
15	Plug
16	Plug
17	O-ring
18	O-ring
19	O-ring
20	O-ring
21	O-ring
22	O-ring
23	Backup ring
24	Pin
25	Handle kit
25 ₁	Screw
25 ₂	Knob
25 ₃	Nut
25 ₄	Screw

Seal Part List (Kit Model Number BRES-03R*)

Part No.	Part Name	Part Number	Q'ty		
			P/A/B	W	PV
17	O-ring	1B-P5	—	—	2
18	O-ring	1B-P7	1	2	1
19	O-ring	1A-P10A	1	2	1
20	O-ring	AS568-014(Hs90)	5	5	5
21	O-ring	1B-P18	2	4	2
22	O-ring	AS568-119(Hs90)	1	2	1
23	Backup ring	T2-P18	1	2	1

Note) 1. O-ring 1A/B-** refers to JIS B2401-1A/B.
2. Backup ring indicates JIS B2407-T2-**.
3. Specify P, W, or PV for the asterisk (*) in the kit model number.



Brake Modular Valve

5.3 to 7.9gpm
114 to 3000,3571psi

Features

① This modular pressure control valve prevents abnormal pressure when the actuator stops, enabling smooth stops.

② Wide ranging applicability
Maximum operating pressure:
25MPa{3571psi}

Pressure Adjustment Range:
0.8 to 21, 25MPa
{114 to 3000, 3571psi}

Specifications

Model No.	Nominal Diameter (Size)	Maximum Working Pressure MPa{psi}	Maximum Flow Rate ℓ /min(gpm)	Pressure Adjustment Range MPa{psi}	Weight kg	Gasket Surface Dimensions
ORO-G01-W1-20 W3	1/8	25 {3571}	20 (5.3)	0.8 to 7{114 to 1000}	1.5	ISO 4401-03-02-0-94
3.5 to 21{500 to 3000}						
0.8 to 7{114 to 1000}						
ORO-G01-A1-20 A3				3.5 to 21{500 to 3000}	1.4	
ORO-G01-B1-20 B3				0.8 to 7{114 to 1000}	1.4	
3.5 to 21{500 to 3000}						
ORO-G03-W1-J50 W3	3/8	25 {3571}	30 (7.9)	0.8 to 7{114 to 1000}	4.8	ISO 4401-05-04-0-94
3.5 to 25{500 to 3571}						
0.8 to 7{114 to 1000}						
ORO-G03-A1-J50 A3				3.5 to 25{500 to 3571}	4.0	
ORO-G03-B1-J50 B3				0.8 to 7{114 to 1000}	4.0	
3.5 to 25{500 to 3571}						

● Handling

① The pressure adjustment range is expressed using cracking pressure.
② For use as a safety valve, use a pressure override that is higher than the required circuit pressure.

③ Note that a sub plate and installation bolts are not included.

Understanding Model Numbers

ORO - G 03 - A 3 - (K) - J50

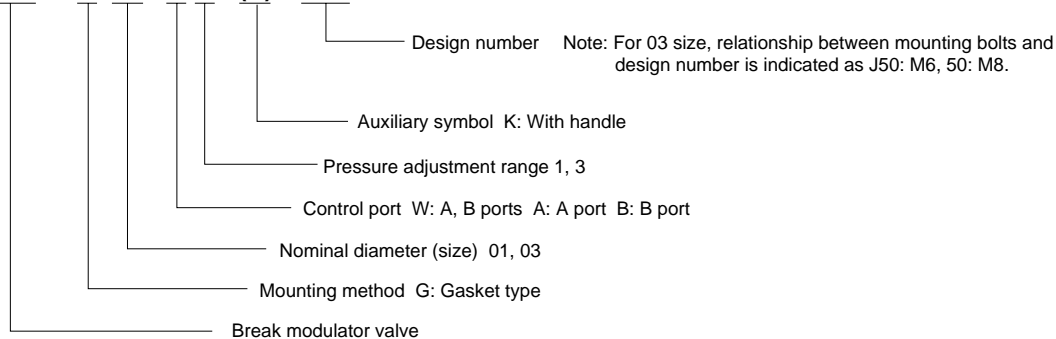

Installation Dimension Drawings

Note) Pressure is increased by clockwise (rightward) rotation of the adjusting screw (bolt), and decreased by counterclockwise (leftward) rotation.

ORO-G01-W*-20

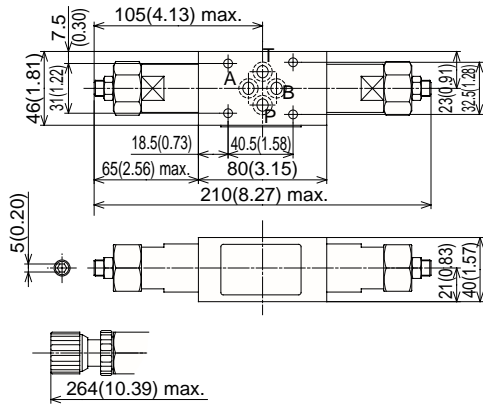

ORO-G01-A*-20

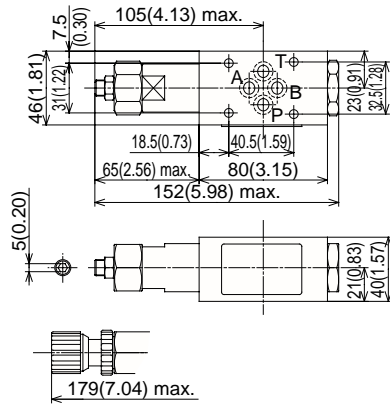

ORO-G01-B*-20

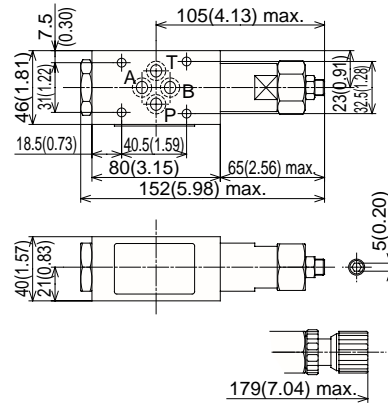

ORO-G03-W*-J50

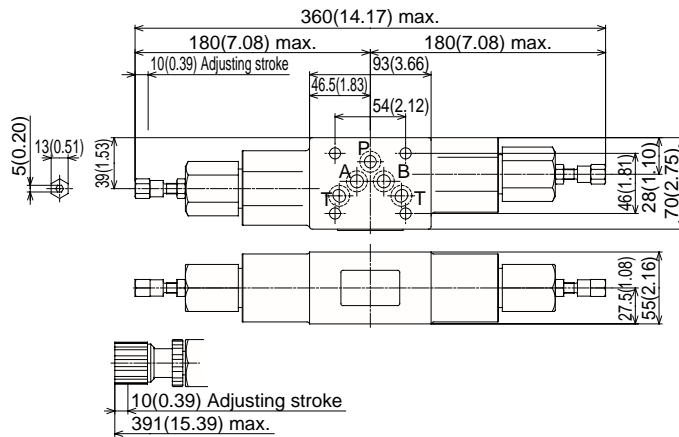

ORO-G03-A*-J50

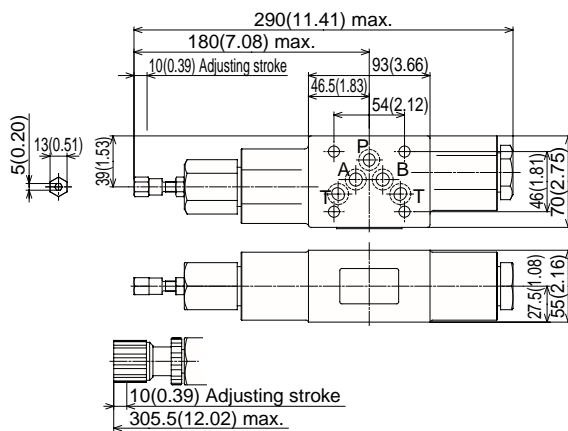

ORO-G03-B*-J50

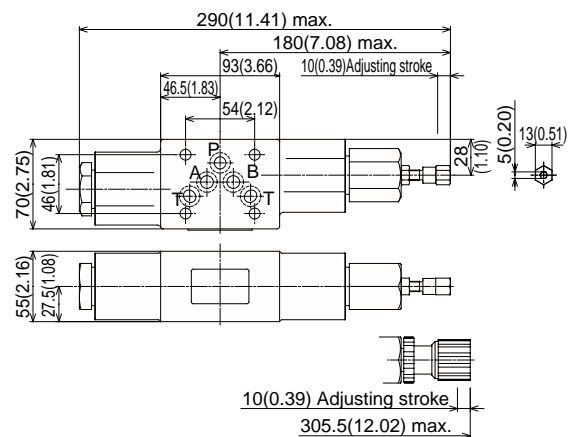

Performance Curves

Differential Hydraulic Fluid Viscosity 32mm²/s

Pressure – Flow Rate Characteristics
ORO-G01-**-20

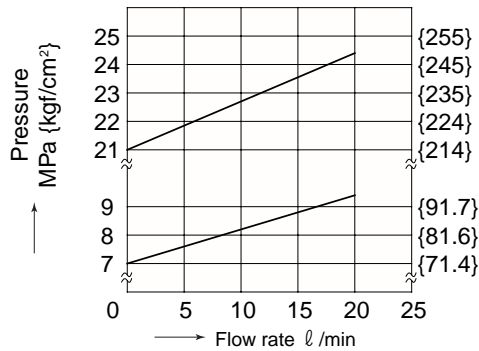

ORO-G03-**-J50

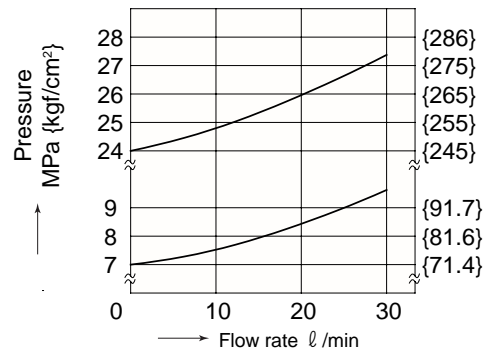

Number of Adjusting Screw Rotations – Pressure Characteristics

ORO-G01-**-20

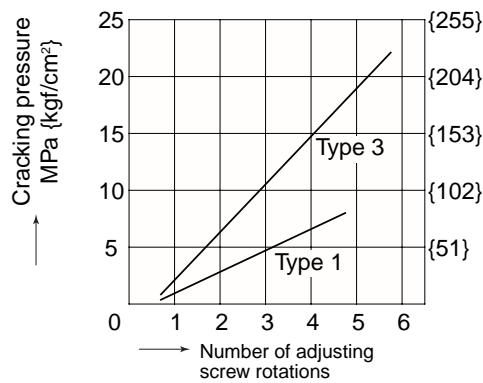

ORO-G03-**-J50

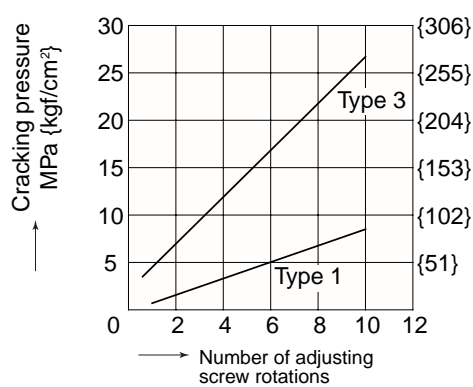

Cross-sectional Drawing

ORO-G01-W*-20

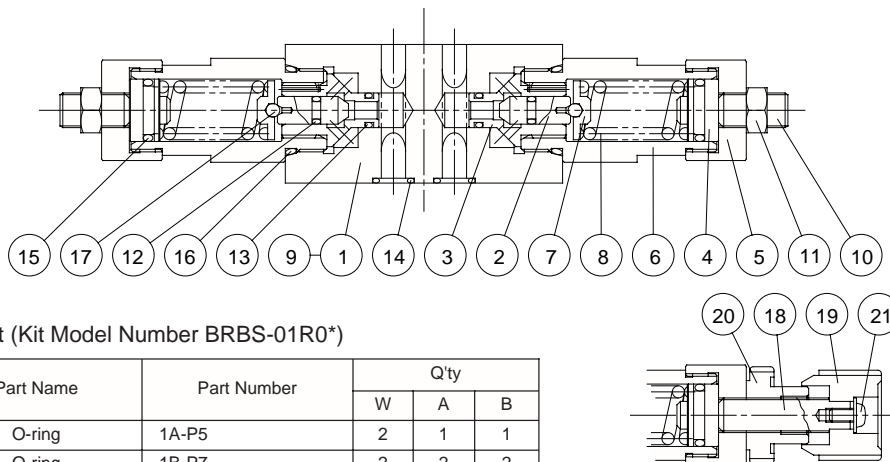

Part No.	Part Name
1	Body
2	Poppet
3	Seat
4	Plunger
5	Bushing
6	Retainer
7	Guide
8	Spring
9	Plate
10	Screw
11	Nut
12	O-ring
13	O-ring
14	O-ring
15	O-ring
16	O-ring
17	Ball
18	Screw
19	Knob
20	Nut
21	Screw

Seal Part List (Kit Model Number BRBS-01R0*)

Part No.	Part Name	Part Number	Q'ty		
			W	A	B
12	O-ring	1A-P5	2	1	1
13	O-ring	1B-P7	2	2	2
14	O-ring	1B-P9	4	4	4
15	O-ring	1B-P14	2	1	1
16	O-ring	1B-P22	2	2	2

Note) 1. O-ring 1A/B-** refers to JIS B2401-1A/B.
2. Specify W, A, or B for the asterisk (*) in the kit model number.

ORO-G03-A*-J50

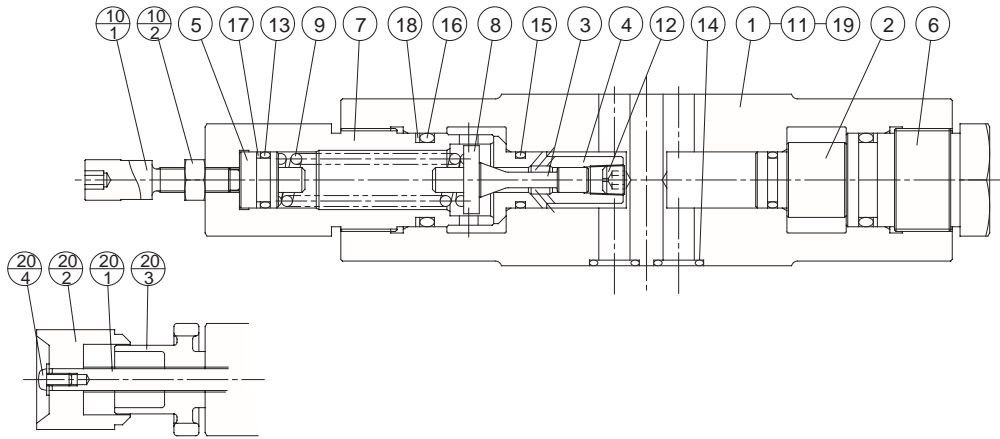

Part No. | Part Name

1	Body
2	Plug
3	Poppet
4	Seat
5	Plunger
6	Bushing
7	Retainer
8	Guide
9	Spring
10	Screw kit
10.1	Screw
10.2	Nut
11	Plate
12	Orifice
13	O-ring
14	O-ring
15	O-ring
16	O-ring
17	Backup ring
18	Backup ring
19	Pin
20	Handle kit
20.1	Screw
20.2	Knob
20.3	Nut
20.4	Screw

Seal Part List (Kit Model Number BRES-03R0*)

Part No.	Part Name	Part Number	Q'ty		
			W	A	B
13	O-ring	1A-P14	2	1	1
14	O-ring	AS568-014(Hs90)	5	5	5
15	O-ring	1B-P14	2	2	2
16	O-ring	1B-P24	2	2	2
17	Backup ring	T2-P14	2	1	1
18	Backup ring	T2-P24	2	2	2

- Note) 1. O-ring 1A/B-** refers to JIS B2401-1A/B.
 2. Backup ring indicates JIS B2407-T2-**.
 3. Specify W, A, or B for the asterisk (*) in the kit model number.

Direct Relief Modular Valve

5.3 to 7.9gpm
114 to 3000,3571psi



Features

① This modular relief valve provides maximum pressure control for a hydraulic circuit.

② Wide ranging applicability
Maximum Working Pressure: 25MPa {3571psi}

Pressure Adjustment Range:
0.8 to 21, 25MPa {114 to 3571psi}

Specifications

Model No.	Nominal Diameter (Size)	Maximum Working Pressure MPa{psi}	Maximum Flow Rate ℓ /min(gpm)	Pressure Adjustment Range MPa{psi}	Weight kg	Gasket Surface Dimensions	
ORD-G01-W1-20 W3	1/8	25{3571}	20 (5.3)	0.8 to 7{114 to 1000}	1.5	ISO 4401-03-02-0-94	
ORD-G01-A1-20 A3				3.5 to 21{500 to 3000}			
ORD-G01-B1-20 B3				0.8 to 7{114 to 1000}	1.4		
ORD-G03-W1-J50 W3	3/8	25{3571}	30 (7.9)	0.8 to 7{114 to 1000}	4.8		ISO 4401-05-04-0-94
ORD-G03-A1-J50 A3				3.5 to 25{500 to 3571}			
ORD-G03-B1-J50 B3				0.8 to 7{114 to 1000}	4.0		

● Handling

- ① The pressure adjustment range is expressed in terms of cracking pressure.
- ② For use as a safety valve, use a pressure override that is higher than the required circuit pressure.

- ③ Tank port back pressure changes cracking pressure by the corresponding amount.
- ④ Note that a sub plate and installation bolts are not included.

Understanding Model Numbers

01, 03 size

ORD - G 03 - W 3 - (K) - J50

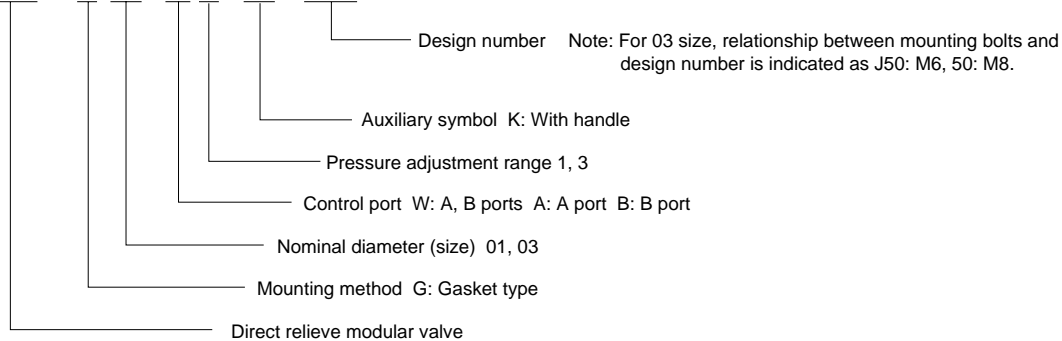

Installation Dimension Drawings

Note)
Pressure is increased by clockwise (rightward) rotation of the adjusting screw (bolt), and decreased by counterclockwise (leftward) rotation.

ORD-G01-W*-20

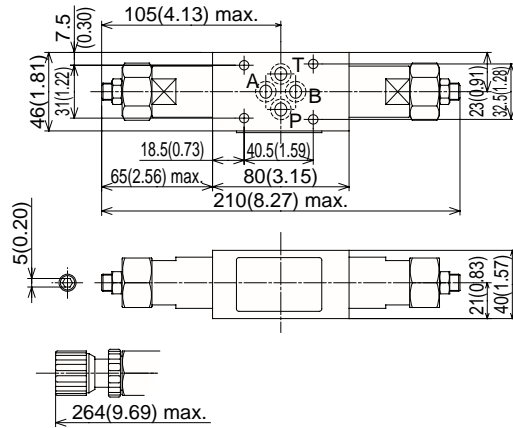

ORD-G01-A*-20

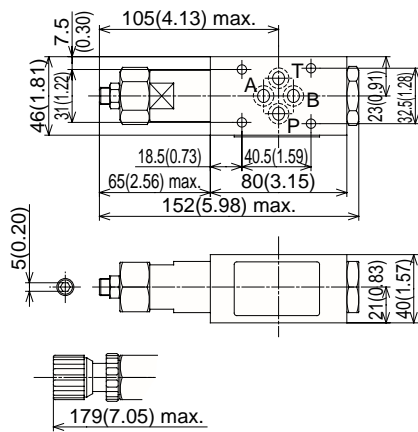

ORD-G01-B*-20

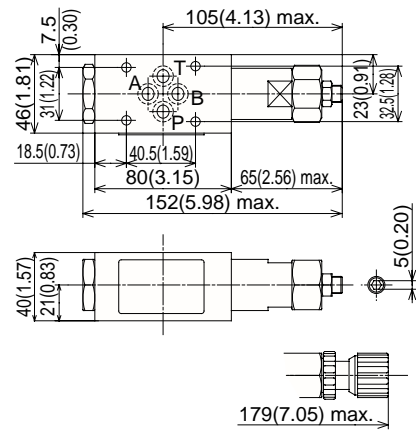

ORD-G03-W*-J50

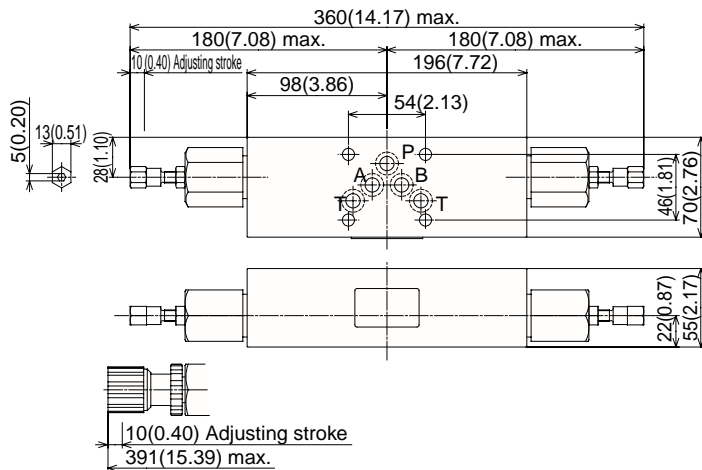

ORD-G03-A*-J50

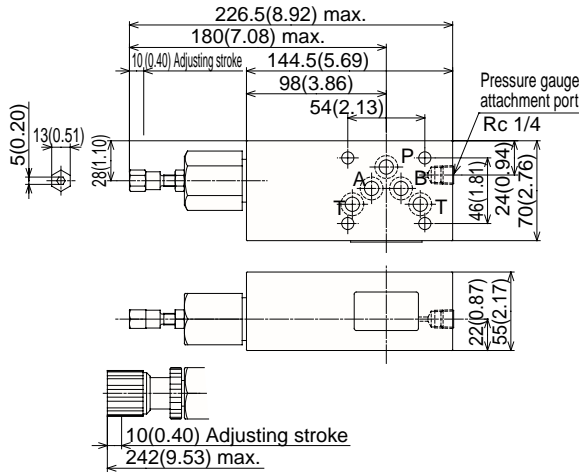

ORD-G03-B*-J50

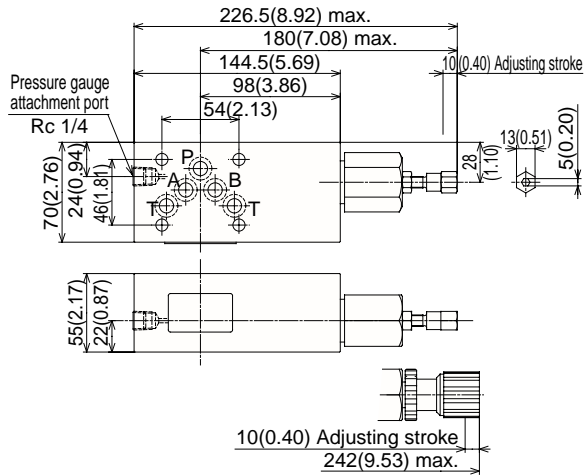

Performance Curves

Differential Hydraulic Fluid Viscosity 32mm²/s

Pressure – Flow Rate Characteristics

ORD-G01-**-20

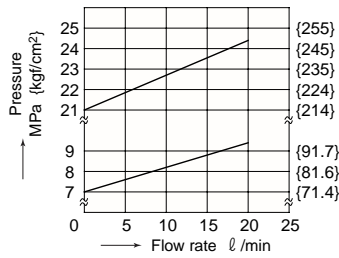

ORD-G03-**-J50

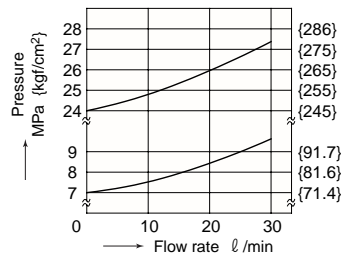

Number of Adjusting Screw Rotations – Pressure Characteristics

ORD-G01-**-20

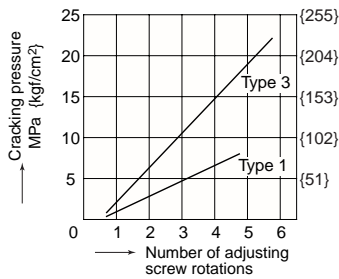

ORD-G03-**-J50

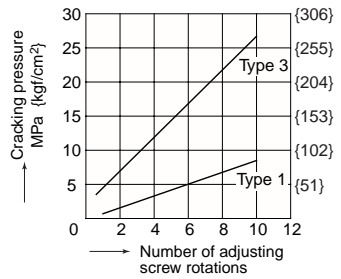

Cross-sectional Drawing

ORD-G01-A*-20

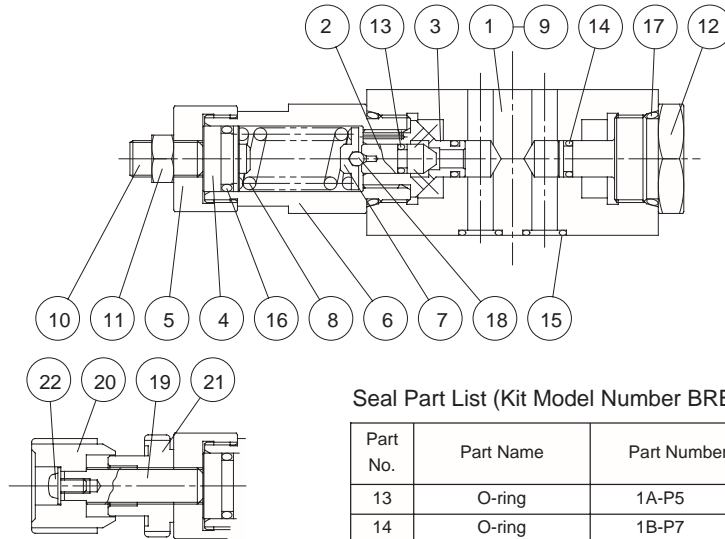

Seal Part List (Kit Model Number BRBS-01RD*)

Part No.	Part Name	Part Number	Q'ty		
			W	A	B
13	O-ring	1A-P5	2	1	1
14	O-ring	1B-P7	2	2	2
15	O-ring	1B-P9	4	4	4
16	O-ring	1B-P14	2	1	1
17	O-ring	1B-P22	2	2	2

Note) 1.O-ring 1A/B-** refers to JIS B2401-1A/B.
2.Specify W, A, or B for the asterisk (*) in the kit model number.

Part No.	Part Name
1	Body
2	Poppet
3	Seat
4	Plunger
5	Bushing
6	Retainer
7	Guide
8	Spring
9	Plate
10	Screw
11	Nut
12	Bushing
13	O-ring
14	O-ring
15	O-ring
16	O-ring
17	O-ring
18	Ball
19	Screw
20	Knob
21	Nut
22	Screw

ORD-G03-A*-J50

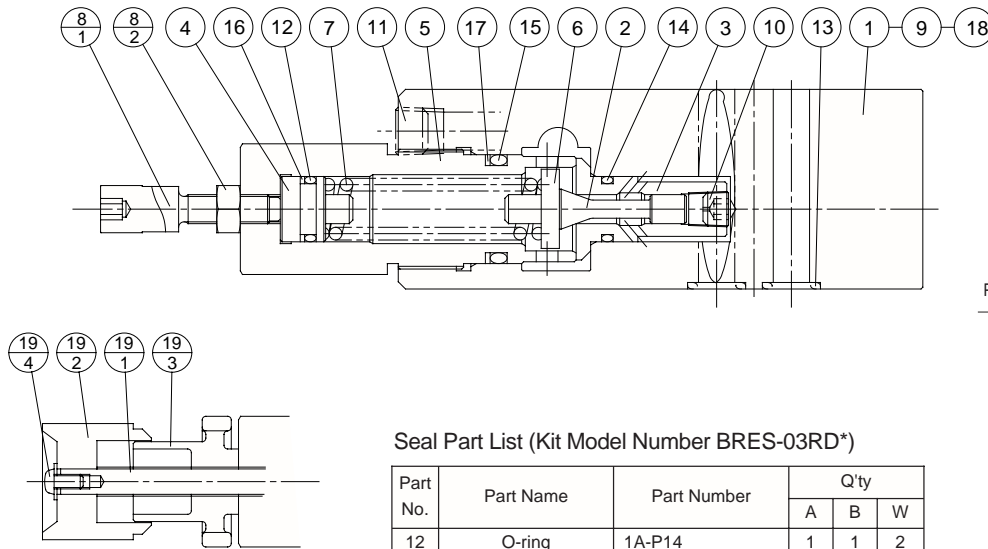

Seal Part List (Kit Model Number BRES-03RD*)

Part No.	Part Name	Part Number	Q'ty		
			A	B	W
12	O-ring	1A-P14	1	1	2
13	O-ring	AS568-014(Hs90)	5	5	5
14	O-ring	1B-P14	1	1	2
15	O-ring	1B-P24	1	1	2
16	Backup ring	T2-P14	1	1	2
17	Backup ring	T2-P24	1	1	2

Note) 1.O-ring 1A/B-** refers to JIS B2401-1A/B.
2.Backup ring indicates JIS B2407-T2-**.
3.Specify W, A, or B for the asterisk (*) in the kit model number.

Part No.	Part Name
1	Body
2	Poppet
3	Seat
4	Plunger
5	Retainer
6	Guide
7	Spring
8	Screw kit
8-1	Screw
8-2	Nut
9	Plate
10	Orifice
11	Plug
12	O-ring
13	O-ring
14	O-ring
15	O-ring
16	Backup ring
17	Backup ring
18	Pin
19	Handle kit
19-1	Screw
19-2	Knob
19-3	Nut
19-4	Screw

Pressure Reducing Modular Valve

10.6 to 21.2gpm
3571psi



Features

- ① This modular valve makes the pressure in part of the circuit lower than that of the main circuit.
- ② Even when pressure changes in the primary main circuit, the reduced secondary pressure is maintained at a constant level.
- ③ Maximum Operating Pressure: 25MPa {3571psi}

Specifications

Model No.	Nominal Diameter (Size)	Maximum Working Pressure MPa{psi}	Maximum Flow Rate ℓ /min(gpm)	Pressure Adjustment Range MPa{psi}	Weight kg	Gasket Surface Dimensions
OG-G01-PC-E21 P1 P2	1/8	25 {3571}	50 (13.2)	0.15 to 3.5{21 to 500} 0.8 to 7{114 to 1000} 3.5 to 16{500 to 3000}	1.3	ISO 4401-03-02-0-94
OG-G03-PC-(V)-E51 P1 P3	3/8	25 {3571}	80(21.1) but C : 50(13.2)	0.25 to 3.5{21 to 500} 0.8 to 7{114 to 1000} 3.5 to 21{500 to 3000}	3.8	ISO 4401-05-04-0-94

● Handling

- ① When using a remote control valve in a vent circuit, certain vent circuit pipe capacities can cause vibration. Because of this, thick steel pipe with an inside diameter of ϕ 4mm that is no longer than three meters is recommended. Vent piping cannot be used with the 01 size. If a vent port is required for the 03 size, add the auxiliary code "V".
- ② For the 03 size, the drainage can be allowed to escape through the T port. In the case of a valve with the auxiliary symbol B, however, run a return pipe from the drain discharge port directly to the tank.
- ③ Note that a change in drain back pressure causes a change in setting pressure.
- ④ With the 01, 03 sizes, the flow rate is limited at low pressures. See the Pressure-Flow Rate Characteristics on pages M-23 and M-24 for more information.
- ⑤ Note that a sub plate and installation bolts are not included.
- ⑥ With the 03 sizes, the control port can be changed by altering the attachment orientation of the back cover. See the installation diagram for more information. After making this change, be sure also to make the other changes in accordance with the model number indicated on the nameplate.

Understanding Model Numbers

01, 03, size

OG - G 03 - P 1 - (B) - E 51

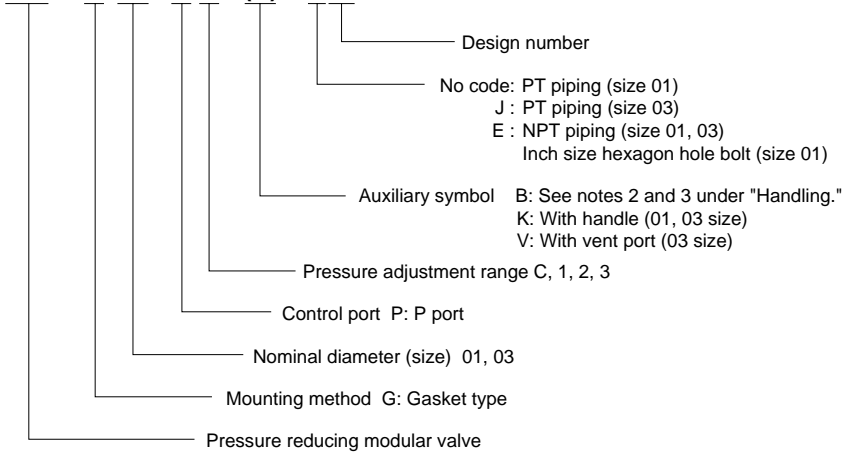

Installation Dimension Drawings

Note)

Pressure is increased by clockwise (rightward) rotation of the adjusting screw (bolt), and decreased by counterclockwise (leftward) rotation.

OG-G01-P*-E21

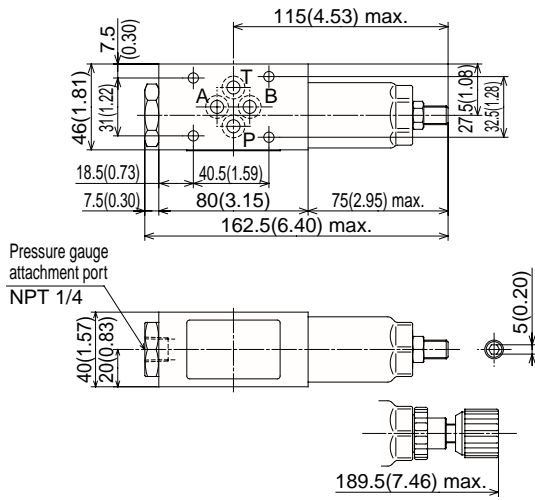

OG-G03-P*(V)-E51

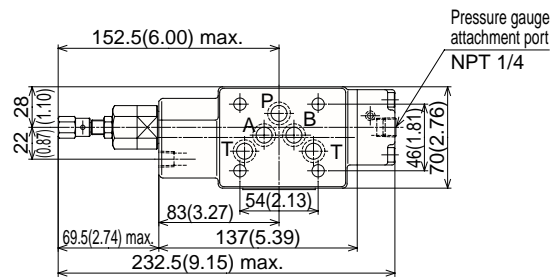

Pressure gauge attachment port
NPT 1/4

OG-G03-P*-J51

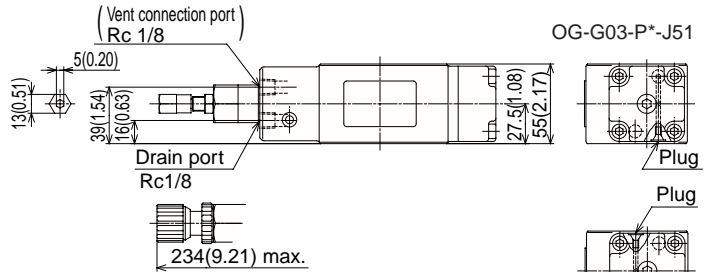

Plug

Plug

OG-G03-B*-J51

- Note) 1. Conversion to B port control is possible by changing the back cover. Port control is determined by plug orientation.
2. When replacing the back cover, be sure also to change the nameplate to the applicable model type.
3. The tightening torque of the back cover bolts is: (M6) 10 to 13Nm (102 to 133 kgf-cm).

Performance Curves

Differential Hydraulic Fluid Viscosity 32mm²/s

Pressure Loss Characteristics

OG-G01-P*-E21

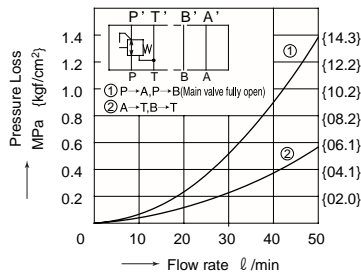

OG-G03-P*-E51

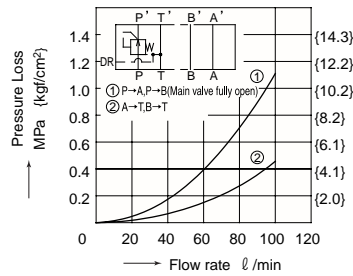

Pressure - Flow Rate Characteristics

OG-G01-P₂-E21

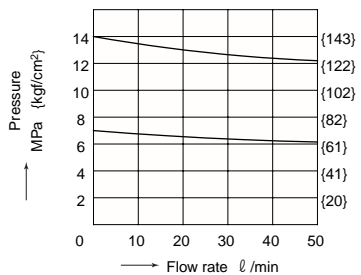

OG-G01-PC-E21

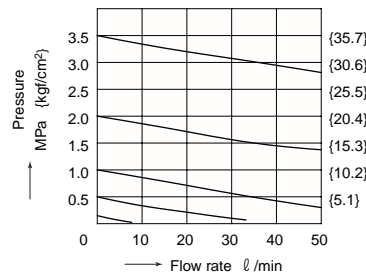

OG-G03-P₃¹-E51

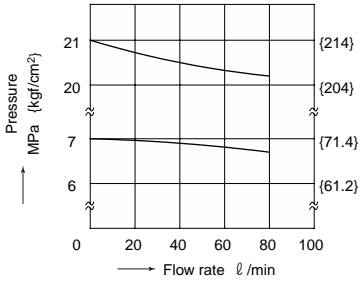

OG-G03-PC-E51

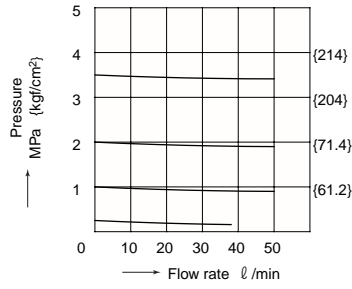

Pressure – Drain Rate Characteristics

OG-G01-P*-E21

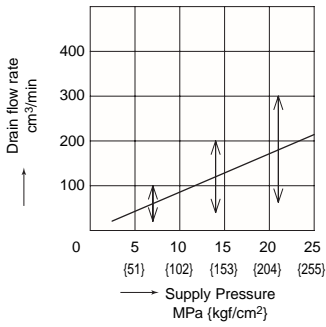

OG-G03-P*-E51

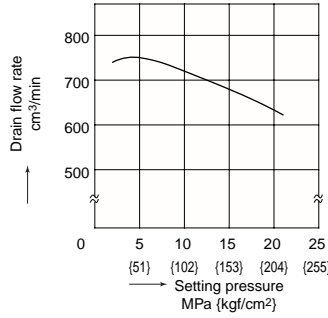

OG-G03-PC-E51

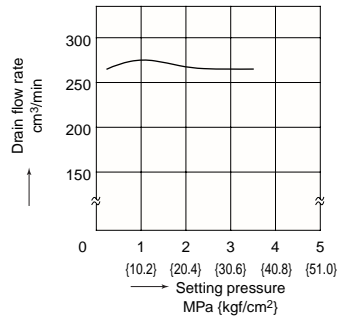

Number of Adjusting Screw Rotations – Pressure Characteristics

OG-G01-P*-E21

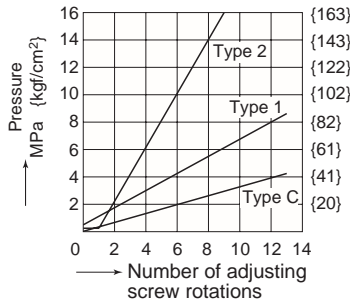

OG-G03-P*-E51

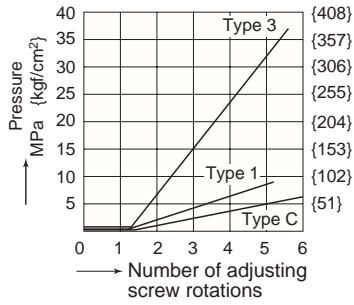

Cross-sectional Drawing

OG-G01-P2-E21

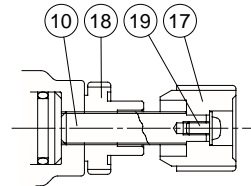
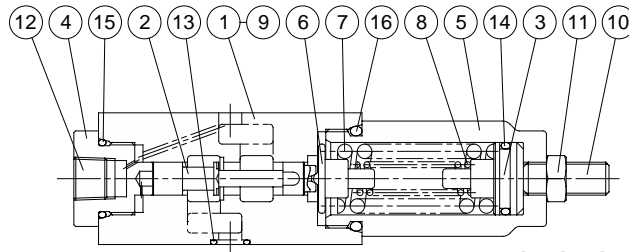

Part No.	Part Name
1	Body
2	Spool
3	Push rod
4	Bushing
5	Retainer
6	Guide
7	Spring
8	Spring
9	Plate
10	Screw
11	Nut
12	Plug
13	O-ring
14	O-ring
15	O-ring
16	O-ring
17	Knob
18	Nut
19	Screw

Seal Part List (Kit Model Number BRBS-01GP*)

Part No.	Part Name	Part Number	Q'ty
			P
13	O-ring	1B-P9	4
14	O-ring	1A-P18	1
15	O-ring	1B-P20	1
16	O-ring	1B-P26	1

Note) O-ring 1A/B-** refers to JIS B2401-1A/B.

Note)
Part number 8 is used in the case of pressure adjustment range type 2 only.

OG-G01-PC-E21

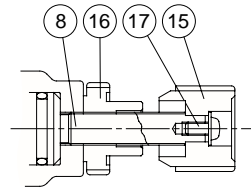
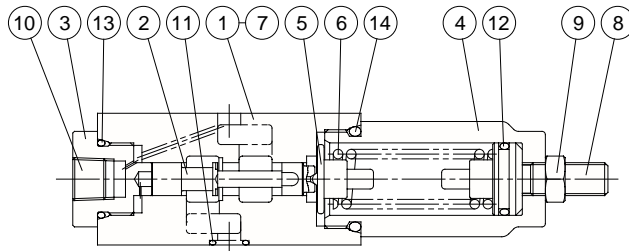

Part No.	Part Name
1	Body
2	Spool
3	Bushing
4	Retainer
5	Guide
6	Spring
7	Plate
8	Screw
9	Nut
10	Plug
11	O-ring
12	O-ring
13	O-ring
14	O-ring
15	Knob
16	Nut
17	Screw

Seal Part List (Kit Model Number BRBS-01GP*)

Part No.	Part Name	Part Number	Q'ty
			P
11	O-ring	1B-P9	4
12	O-ring	1A-P18	1
13	O-ring	1B-P20	1
14	O-ring	1B-P26	1

Note) O-ring 1A/B-** refers to JIS B2401-1A/B.

OG-G03-P*-E51

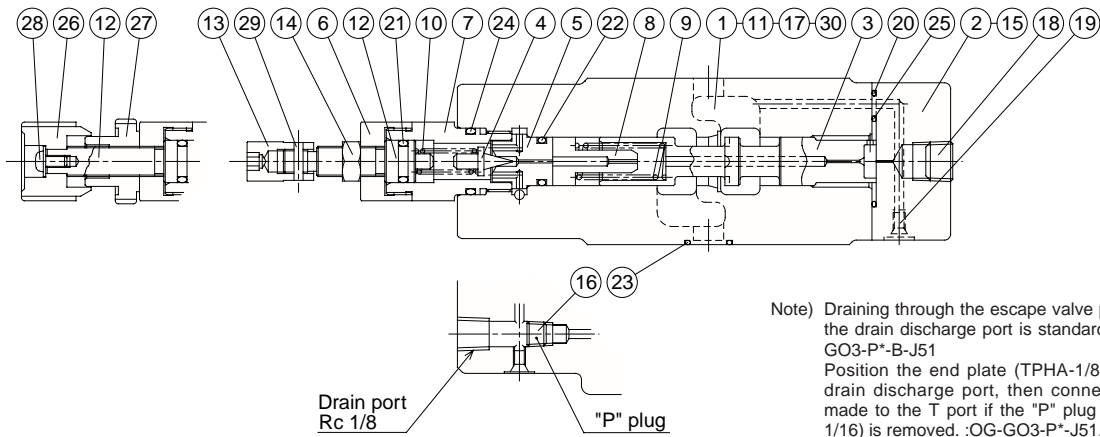

Note) Draining through the escape valve piped to the drain discharge port is standard. : OG-G03-P*-B-J51
Position the end plate (TPHA-1/8) to the drain discharge port, then connection is made to the T port if the "P" plug (TPUA-1/16) is removed. :OG-G03-P*-J51.

Seal Part List (Kit Model Number BRES-03GP-1A)

Part No.	Part Name	Part Number	Q'ty	
			P	
20	O-ring	1B-P6	2	
21	O-ring	1A-P10A	1	
22	O-ring	1B-P12	1	
23	O-ring	AS568-014(Hs90)	5	
24	O-ring	1B-P18	1	
25	O-ring	AS568-023(Hs90)	1	

Note) O-ring 1A/B-** refers to JIS B2401-1A/B.

Part No.	Part Name	Part No.	Part Name
1	Body	14	Nut
2	Cover	15	Screw
3	Spool	16	Plug
4	Poppet	17	Plug
5	Seat	18	Plug
6	Bushing	19	Plug
7	Retainer	20	O-ring
8	Choke	21	O-ring
9	Spring	22	O-ring
10	Spring	23	O-ring
11	Plate	24	O-ring
12	Screw	25	O-ring
13	Nut	26	Knob
		27	Nut
		28	Screw
		29	Pin
		30	Pin

OG-G03-PC-E51

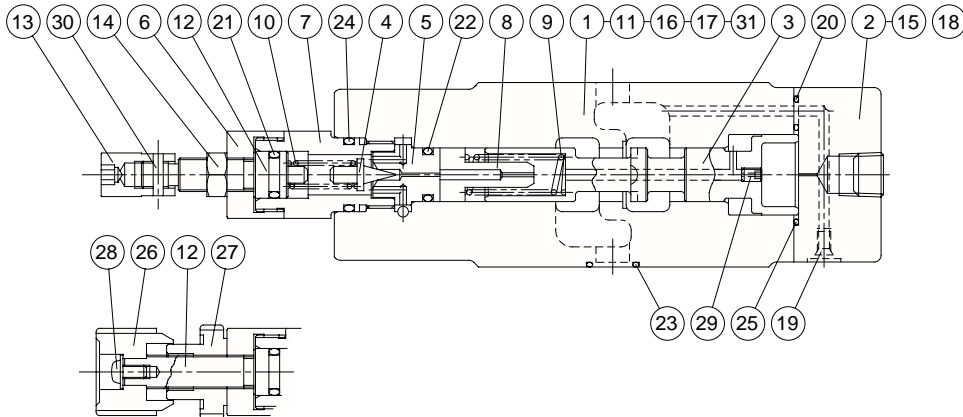

Seal Part List (Kit Model Number BRES-03GP*-1A)

Part No.	Part Name	Part Number	Q'ty	
			P	
20	O-ring	1B-P6	2	
21	O-ring	1A-P10A	1	
22	O-ring	1B-P12	1	
23	O-ring	AS568-014(Hs90)	5	
24	O-ring	1B-P18	1	
25	O-ring	AS568-023(Hs90)	1	

Note) O-ring 1A/B-** refers to JIS B2401-1A/B.

Part No.	Part Name	Part No.	Part Name
1	Body	16	Plug
2	Cover	17	Plug
3	Spool	18	Plug
4	Poppet	19	Plug
5	Seat	20	O-ring
6	Bushing	21	O-ring
7	Retainer	22	O-ring
8	Choke	23	O-ring
9	Spring	24	O-ring
10	Spring	25	O-ring
11	Plate	26	Knob
12	Screw	27	Nut
13	Nut	28	Screw
14	Nut	29	Choke
15	Screw	30	Pin
		31	Pin



Pressure Reducing Modular Valve

10.6 to 21.2gpm
3571psi

Features

- ① This modular valve makes the pressure in part of the circuit lower than the main circuit.
- ② Even when pressure changes in the primary main circuit, the reduced secondary pressure is maintained at a constant level.
- ③ Maximum Operating Pressure: 25MPa {3571psi}

Specifications

Model No.	Nominal Diameter (Size)	Maximum Working Pressure MPa{psi}	Maximum Flow Rate ℓ /min{gpm}	Pressure Adjustment Range MPa{psi}	Weight kg	Gasket Surface Dimensions
OG-G01-AC-E21 A1 A2	1/8	25{3571}	40 (10.6)	0.15 to 3.5{21 to 500}	1.3	ISO 4401-03-02-0-94
OG-G01-BC-E21 B1 B2				0.8 to 7{114 to 1000}		
OG-G03-AC-E51 A1 A3	3/8	25{3571}	80{21.1} but C : 50{13.2}	0.15 to 3.5{21 to 500}	1.3	
OG-G03-BC-E51 B1 B3				0.8 to 7{114 to 1000}		
				0.25 to 3.5{35 to 500}	3.8	ISO 4401-05-04-0-94
				0.8 to 7{114 to 1000}	3.8	
				0.25 to 3.5{35 to 500}		
				0.8 to 7{114 to 1000}		
				3.5 to 21{500 to 3000}		

● Handling

- ① When using a remote control valve in a vent circuit, certain vent circuit pipe capacities can cause vibration. Because of this, thick steel pipe with an inside diameter of ϕ 4mm that is no longer than three meters is recommended. Vent piping cannot be used with the 01, 03 sizes.
- ② With the 01, 03 sizes, the flow rate is limited at low pressures. See the Pressure-

Flow Rate Characteristics on page M-31 and M-32 for more information.

- ③ For the 03 size, the drainage can be allowed to escape through the T port. In the case of a valve with the auxiliary symbol B, however, run a return pipe from the drain discharge port directly to the tank.

Understanding Model Numbers

OG - G 03 - B 1 - (B) - E51

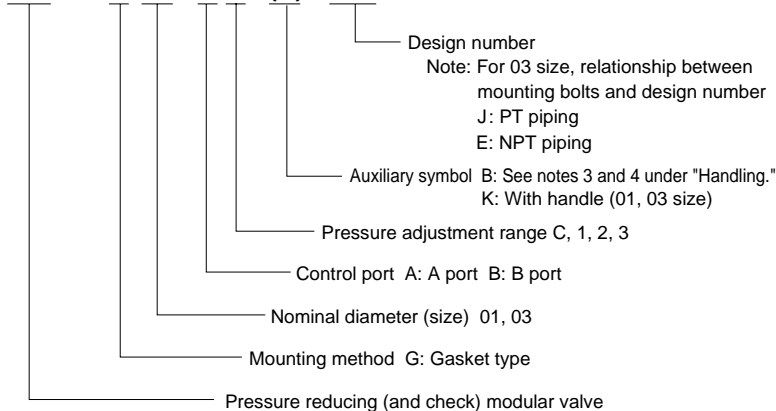

- ④ Note that a change in drain back pressure causes a change in setting pressure.

- ⑤ Note that a sub plate and installation bolts are not included.

- ⑥ With the 03 sizes, the control port can be changed by altering the attachment orientation of the back cover. See the installation diagram for more information. After making this change, be sure also to make the other changes as in accordance with the model number indicated on the nameplate.

Installation Dimension Drawings

Note)
Pressure is increased by clockwise (rightward) rotation of the adjusting screw (bolt), and decreased by counterclockwise (leftward) rotation.

OG-G01-A*-E21

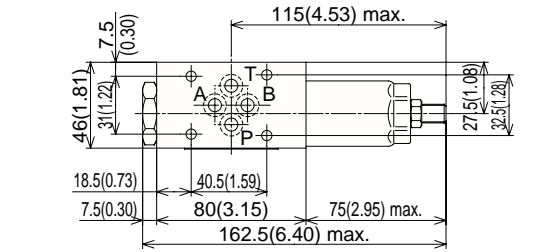

OG-G01-B*-E21

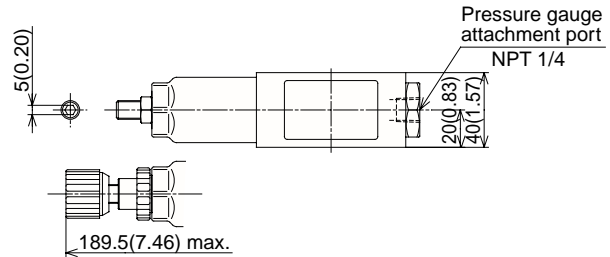
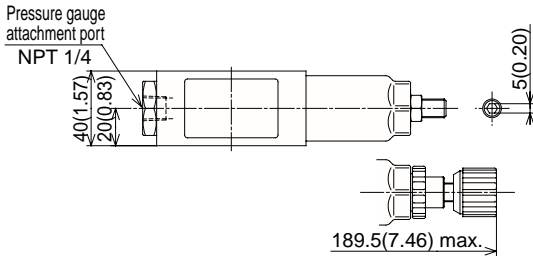
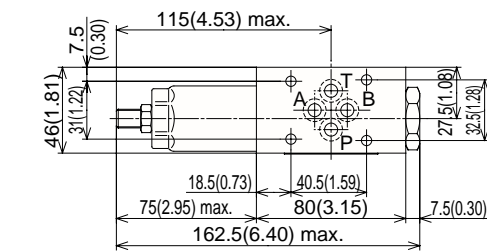

OG-G03-A*-E51

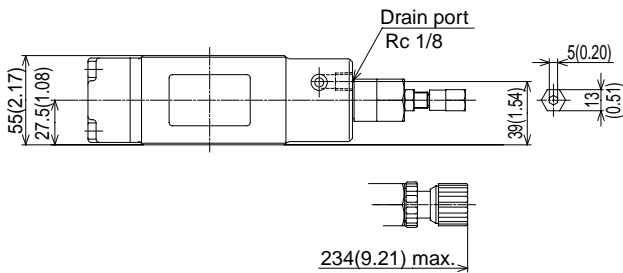
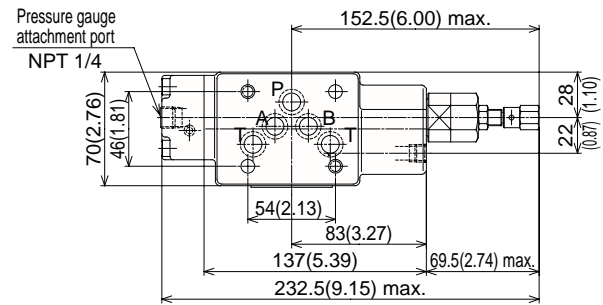

OG-G03-B*-E51

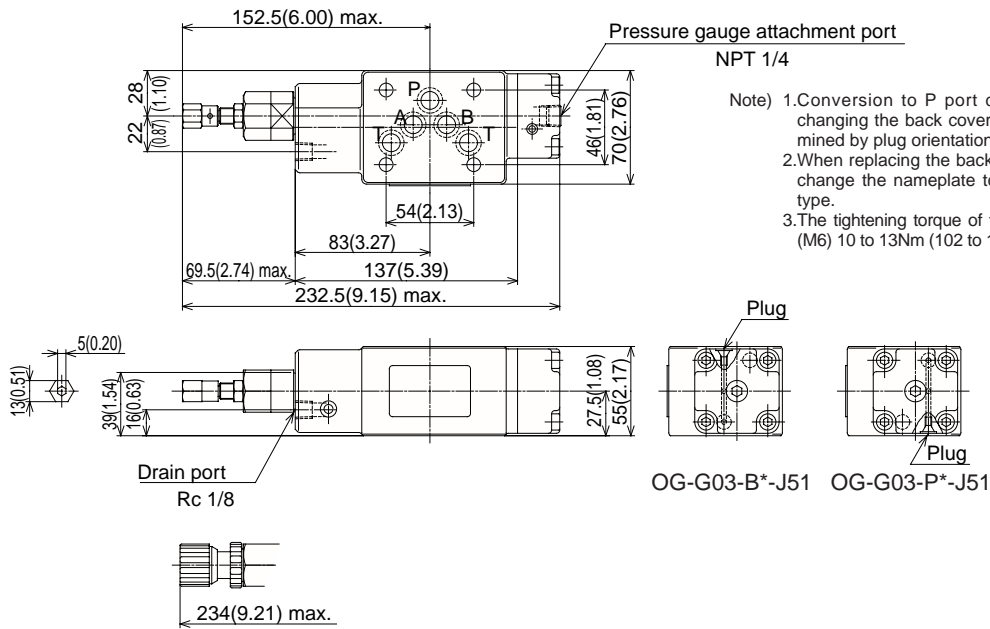

Performance Curves

Hydraulic Operating Fluid Viscosity 32mm²/s

Pressure Loss Curve

OG-G01-B*-E21

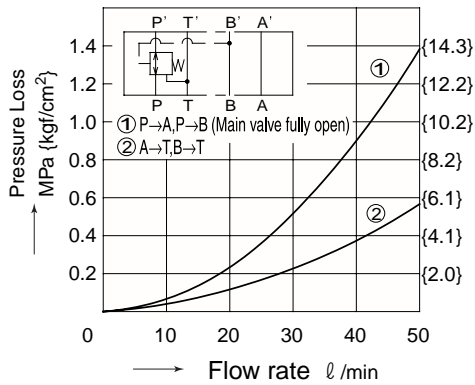

OG-G03-B*-E51

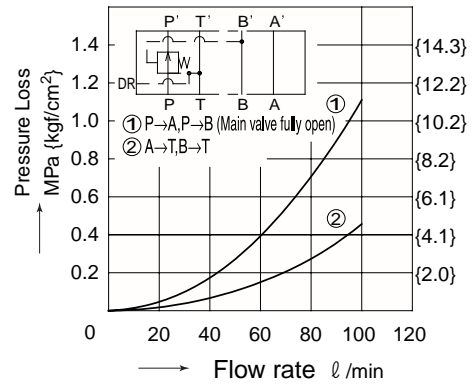

Pressure – Flow Rate Characteristics

OG-G01-B₂¹-E21

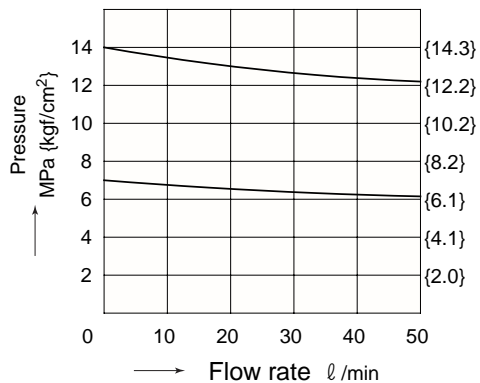

OG-G01-BC-E21

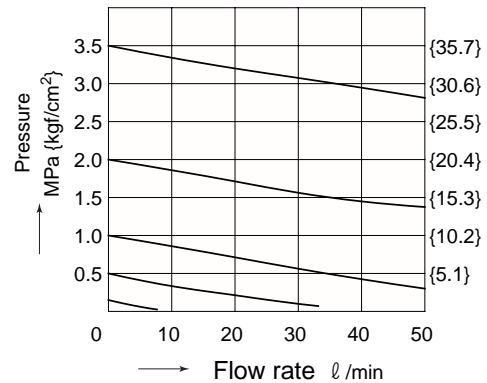

OG-G03-B₃¹-E51

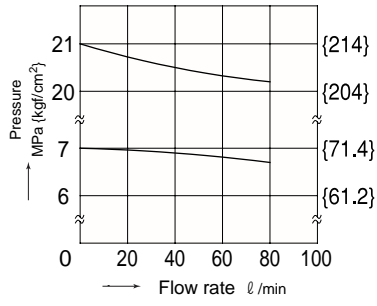

OG-G03-BC-E51

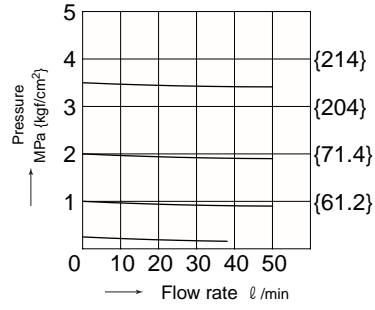

Pressure – Drain Rate Characteristics

OG-G03-B*-E51

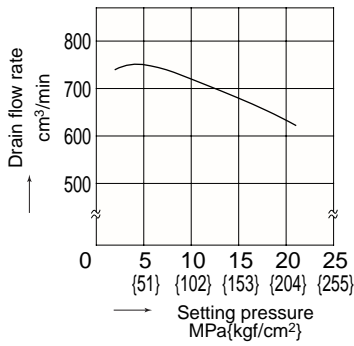

OG-G03-BC-E51

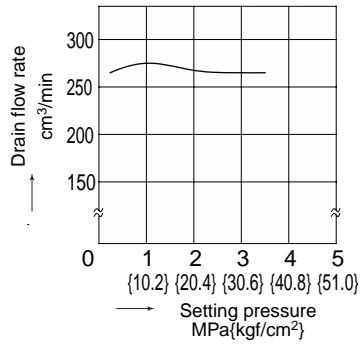

Number of Adjusting Screw Rotations – Pressure Characteristics

OG-G01-**-E21

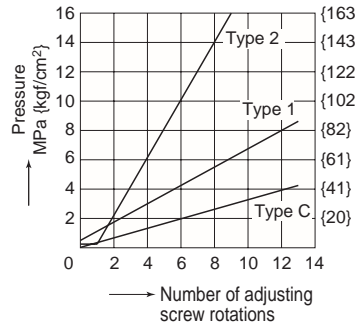

OG-G03-**-*-E51

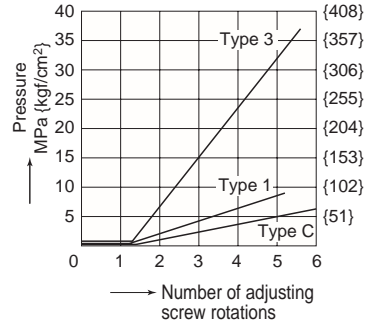

Cross-section

OG-G01-A2-E21

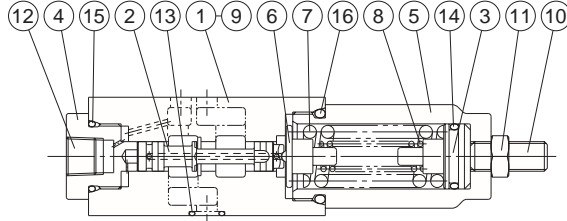

Part No.	Part Name
1	Body
2	Spool
3	Push rod
4	Bushing
5	Retainer
6	Guide
7	Spring
8	Spring
9	Plate
10	Screw
11	Nut
12	Plug
13	O-ring
14	O-ring
15	O-ring
16	O-ring
17	Knob
18	Nut
19	Screw

Seal Part List (Kit Model Number BRBS-01GP*)

Part No.	Part Name	Part Number	Q'ty
13	O-ring	1B-P9	4
14	O-ring	1A-P18	1
15	O-ring	1B-P20	1
16	O-ring	1B-P26	1

Note) O-ring 1A/B-** refers to JIS B2401-1A/B.

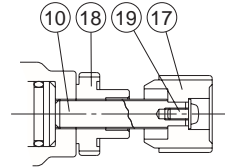

Note)

Part number 8 is used in the case of pressure adjustment range type 2 only.

OG-G01-AC-E21

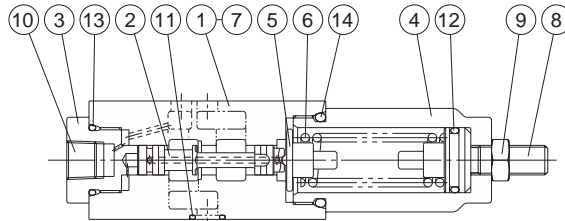

Part No.	Part Name
1	Body
2	Spool
3	Bushing
4	Retainer
5	Guide
6	Spring
7	Plate
8	Screw
9	Nut
10	Plug
11	O-ring
12	O-ring
13	O-ring
14	O-ring
15	Knob
16	Nut
17	Screw

Seal Part List (Kit Model Number BRBS-01GP*)

Part No.	Part Name	Part Number	Q'ty
11	O-ring	1B-P9	4
12	O-ring	1A-P18	1
13	O-ring	1B-P20	1
14	O-ring	1B-P26	1

Note) O-ring 1A/B-** refers to JIS B2401-1A/B.

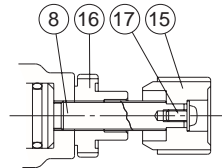

OG-G03-B*-E51

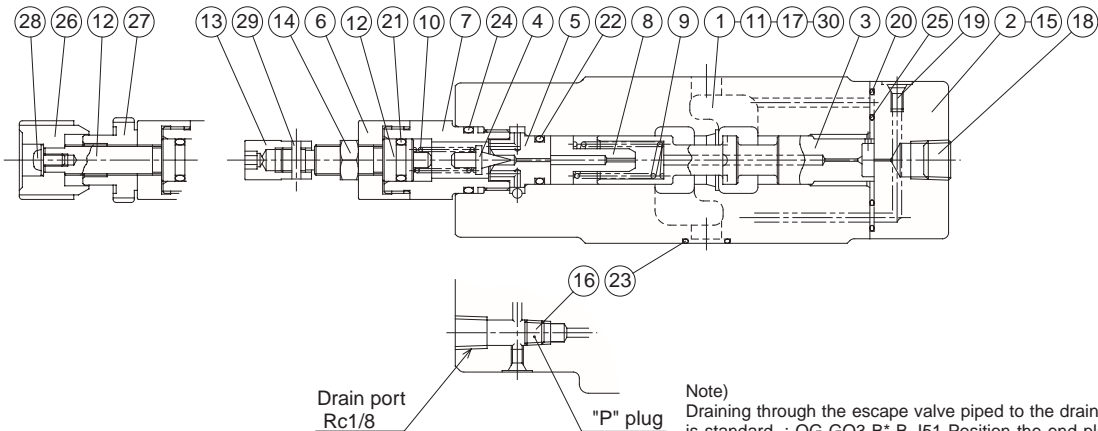

Note)

Draining through the escape valve piped to the drain discharge port is standard. : OG-G03-B*-B-J51 Position the end plate (TPHA-1/8) to the drain discharge port, then connection is made to the T port if the "P" plug (TPUA-1/16) is removed. :OG-G03-B*-J51.

Seal Part List (Kit Model Number BRES-03G*-1A)

Part No.	Part Name	Part Number	Q'ty	
			A	B
20	O-ring	1B-P6	2	2
21	O-ring	1A-P10A	1	1
22	O-ring	1B-P12	1	1
23	O-ring	AS568-014(Hs90)	5	5
24	O-ring	1B-P18	1	1
25	O-ring	AS568-023(Hs90)	1	1

Note) 1.O-ring 1A/B-** refers to JIS B2401-1A/B.

2.Specify A or B for the asterisk (*) in the kit model number.

Part No.	Part Name	Part No.	Part Name	Part No.	Part Name
1	Body	11	Plate	21	O-ring
2	Cover	12	Screw	22	O-ring
3	Spool	13	Nut	23	O-ring
4	Poppet	14	Nut	24	O-ring
5	Seat	15	Screw	25	O-ring
6	Bushing	16	Plug	26	Knob
7	Retainer	17	Plug	27	Nut
8	Choke	18	Plug	28	Screw
9	Spring	19	Plug	29	Pin
10	Spring	20	O-ring	30	Pin

OG-G03-BC-E51

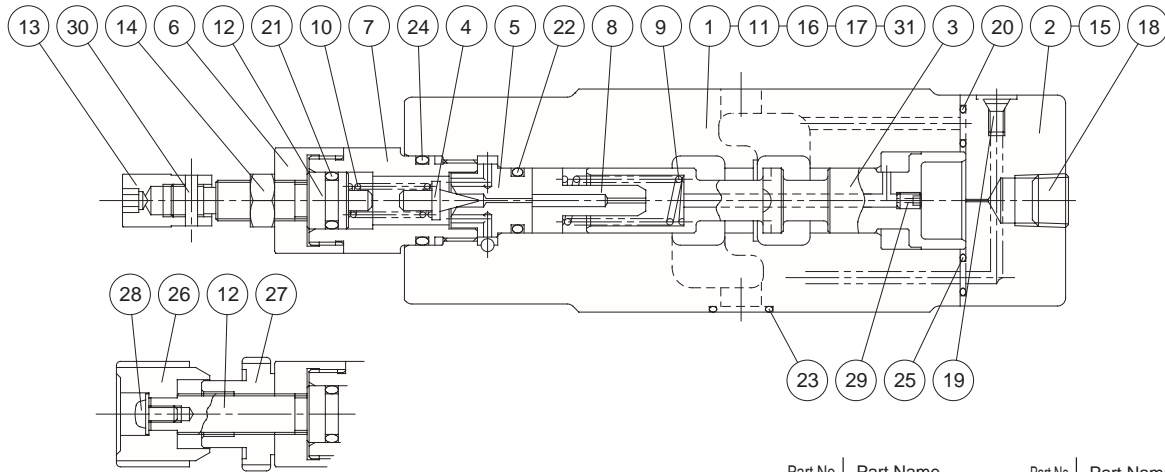

Seal Part List (Kit Model Number BRES-03GC*-1A)

Part No.	Part Name	Part Number	Q'ty	
			A	B
20	O-ring	1B-P6	2	2
21	O-ring	1A-P10A	1	1
22	O-ring	1B-P12	1	1
23	O-ring	AS568-014(Hs90)	5	5
24	O-ring	1B-P18	1	1
25	O-ring	AS568-023(Hs90)	1	1

Note) 1.O-ring 1A/B-** refers to JIS B2401-1A/B.
 2.Specify A or B for the asterisk (*) in the kit model number.

Part No.	Part Name	Part No.	Part Name
1	Body	16	Plug
2	Cover	17	Plug
3	Spool	18	Plug
4	Poppet	19	Plug
5	Seat	20	O-ring
6	Bushing	21	O-ring
7	Retainer	22	O-ring
8	Choke	23	O-ring
9	Spring	24	O-ring
10	Spring	25	O-ring
11	Plate	26	Knob
12	Screw	27	Nut
13	Nut	28	Screw
14	Nut	29	Choke
15	Screw	30	Pin
		31	Pin

Sequence Modular Valve

10.6 to 21.2gpm
3571psi



Features

- ① This modular valve is a pressure control valve used for sequential actuator operations and for maintaining main circuit pressure.
- ② Pressure adjustment is possible across a wide range, from 35 to 3000psi.
- ③ Maximum Operating Pressure: 25MPa {3571psi}

Specifications

Model No.	Nominal Diameter (Size)	Maximum Working Pressure MPa(psi)	Maximum Flow Rate ℓ /min(gpm)	Pressure Adjustment Range MPa(kgf/cm ²)	Weight kg	Gasket Surface Dimensions
OQ-G01-P21-20 P23	1/8	25{3571}	40 (10.5)	0.8 to 7{114 to 1000} 3.5 to 21{500 to 3000}	1.1	ISO 4401-03-02-0-94
OQ-G03-P2A-J50 P2C P2E	3/8	25{3571}	80 (21.1)	0.25 to 0.85{35 to 122} 0.85 to 3.5 {122 to 500} 3.5 to 14{500 to 2000}	3.5	ISO 4401-05-04-0-94

Understanding Model Numbers

OQ - G 03 - P 2 A - (K) - J50

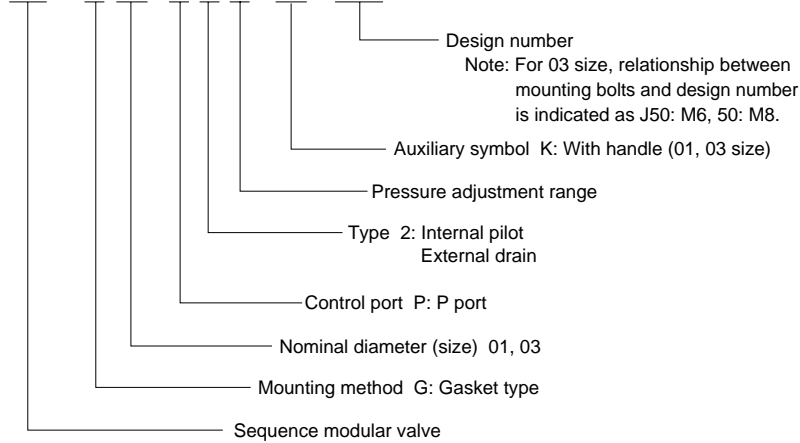

● Handling

- ① The pressure adjustment range is expressed in terms of cracking pressure.
- ② Install this valve directly above the sub plate or manifold.
- ③ When two or more of these valves are ganged in sequence, make sure the setting pressure differential between them is at least 1MPa {10.2kgf/cm²}.
- ④ Note that a sub plate and installation bolts are not included.

Installation Dimension Drawings

Note) Pressure is increased by clockwise (rightward) rotation of the adjusting screw (bolt), and decreased by counterclockwise (leftward) rotation.

OQ-G01-P2*-20

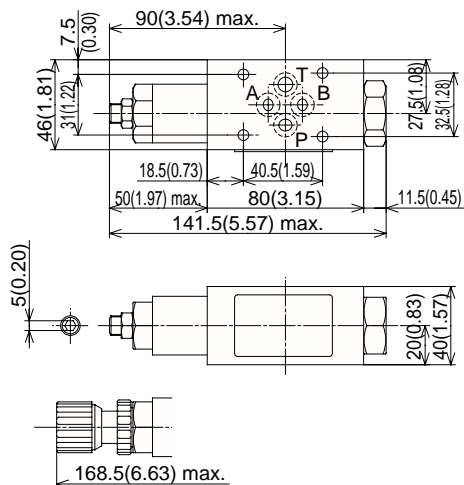

OQ-G03-P2*-J50

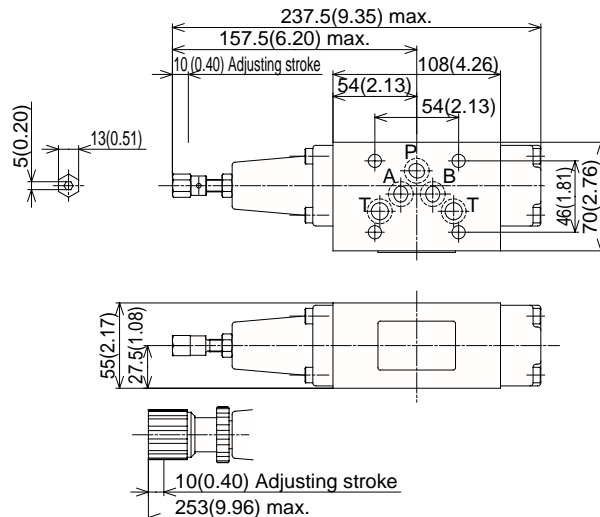

Performance Curves

Hydraulic Operating Fluid Viscosity 32mm²/s

Pressure Loss Characteristics

OQ-G01-P2*-20

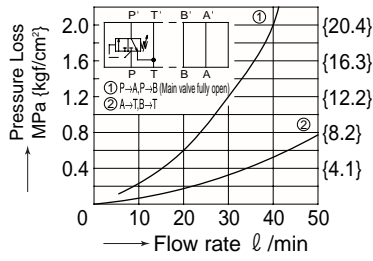

OQ-G03-P2A-J50

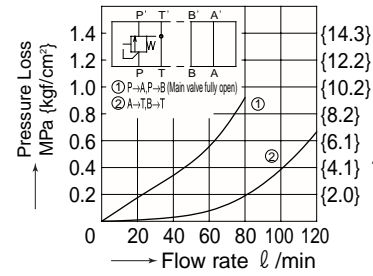

Pressure — Flow Rate Characteristics

OQ-G01-P2*-20

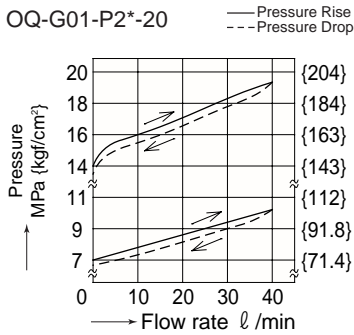

OQ-G03-P2*-J50

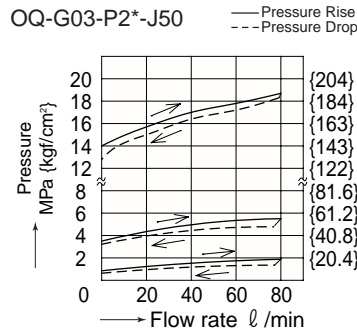

Number of Adjusting Screw Rotations — Pressure Characteristics

OQ-G01-P2*-20

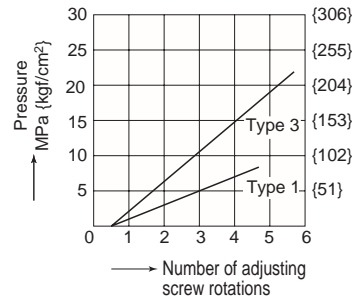

OQ-G03-P2*-J50

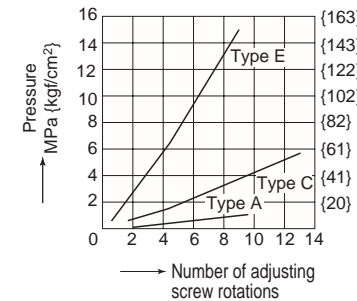

Cross-sectional Drawing

OQ-G01-P2*-20

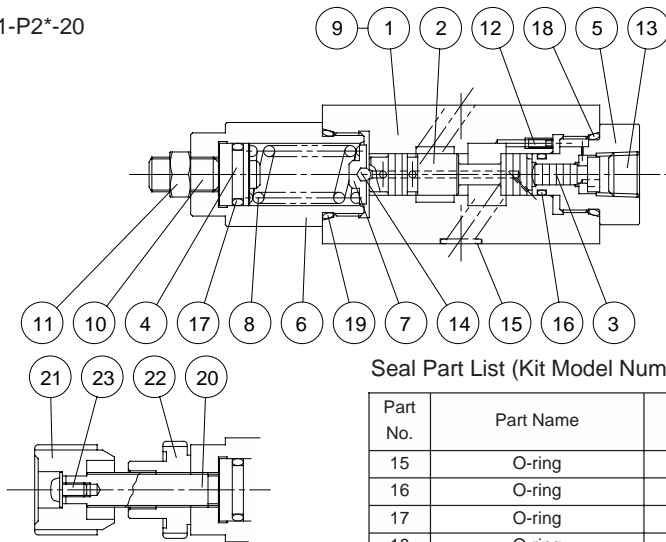

Seal Part List (Kit Model Number BRBS-01QP)

Part No.	Part Name	Part Number	Q'ty	
				P
15	O-ring	1B-P9	4	
16	O-ring	1B-P9	1	
17	O-ring	1A-P14	1	
18	O-ring	1B-P20	1	
19	O-ring	1B-P22	1	

Note) O-ring 1A/B-** refers to JIS B2401-1A/B.

Part No.	Part Name
1	Body
2	Spool
3	Piston
4	Plunger
5	Bushing
6	Retainer
7	Guide
8	Spring
9	Plate
10	Screw
11	Nut
12	Choke
13	Plug
14	Ball
15	O-ring
16	O-ring
17	O-ring
18	O-ring
19	O-ring
20	Screw
21	Knob
22	Nut
23	Screw

OQ-G03-P2*-J50

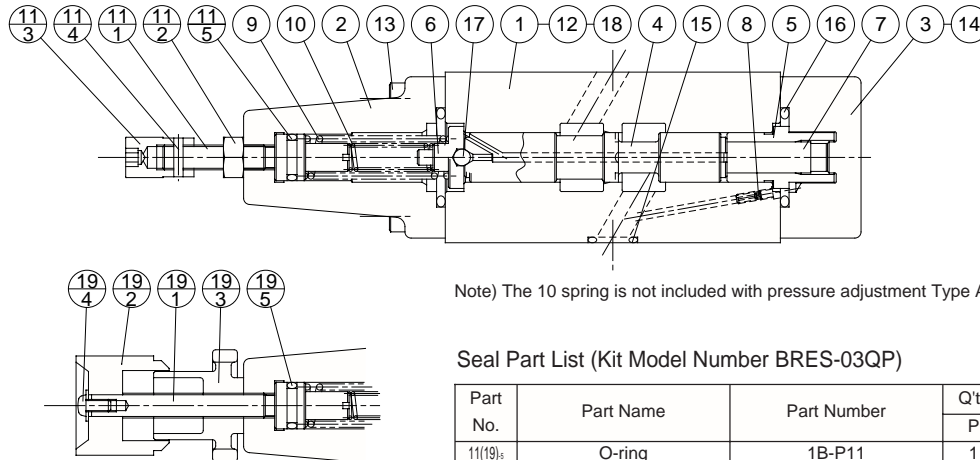

Note) The 10 spring is not included with pressure adjustment Type A.

Seal Part List (Kit Model Number BRES-03QP)

Part No.	Part Name	Part Number	Q'ty	
				P
11(19) _s	O-ring	1B-P11	1	
15	O-ring	AS568-014(Hs90)	5	
16	O-ring	1B-P26	2	

Note) O-ring 1A/B-** refers to JIS B2401-1A/B.

Part No.	Part Name
1	Body
2	Cover
3	Cover
4	Spool
5	Sleeve
6	Guide
7	Plunger
8	Choke
9	Spring
10	Spring
11	Screw kit
11 ₁	Screw
11 ₂	Nut
11 ₃	Nut
11 ₄	Pin
11 ₅	O-ring
12	Plate
13	Screw
14	Screw
15	O-ring
16	O-ring
17	Ball
18	Pin
19	Handle kit
19 ₁	Screw
19 ₂	Knob
19 ₃	Nut
19 ₄	Screw
19 ₅	O-ring



Counter Balance Modular Valve

10.6 to 21.2gpm
2000psi

Features

- ① This modular valve is used to control actuator back pressure and for other pressure control valve applications.
- ② Pressure adjustment is possible across a wide range, from 35 to 2000psi.
- ③ Maximum Operating Pressure: 3571psi

Specifications

Model No.	Nominal Diameter (Size)	Maximum Working Pressure MPa(psi)	Maximum Flow Rate ℓ /min(gpm)	Pressure Adjustment Range MPa(psi)	Weight kg	Gasket Surface Dimensions
OCQ-G01-A11-20 A12	1/8	25{3571}	40 (10.5)	0.8 to 7{114 to 1000}	1.1	ISO 4401-03-02-0-94
OCQ-G01-B11-20 B12				3.5 to 14{500 to 2000}		
OCQ-G03-A1A-J50 A1C A1E	3/8	25{3571}	80 (21.1)	0.25 to 0.85{35 to 114}	3.5	
OCQ-G03-B1A-J50 B1C B1E				0.85 to 3.5{114 to 500}		
				0.25 to 0.85{35 to 114}	3.5	ISO 4401-05-04-0-94
				0.85 to 3.5{114 to 500}		
				3.5 to 14{500 to 2000}		

• Handling

- ① The pressure adjustment range is expressed in terms of cracking pressure.
- ② Run tank port piping directly to the tank, and ensure that back pressure is as small as possible.
- ③ Note that a sub plate and installation bolts are not included.

Understanding Model Numbers

01, 03 size

OCQ - G 03 - B 1 A - (K) - J50

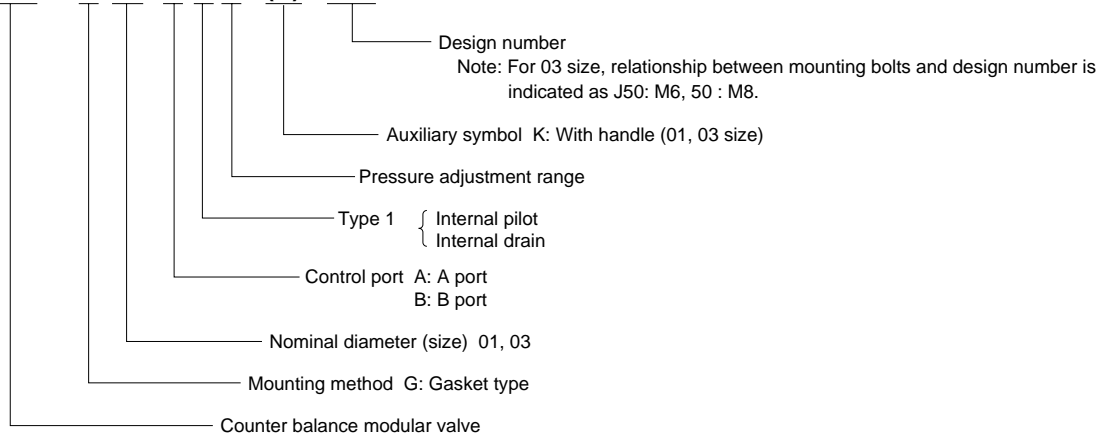

Installation Dimension Drawings

Note) Pressure is increased by clockwise (rightward) rotation of the adjusting screw (bolt), and decreased by counterclockwise (leftward) rotation.

OCQ-G01-A1*-20

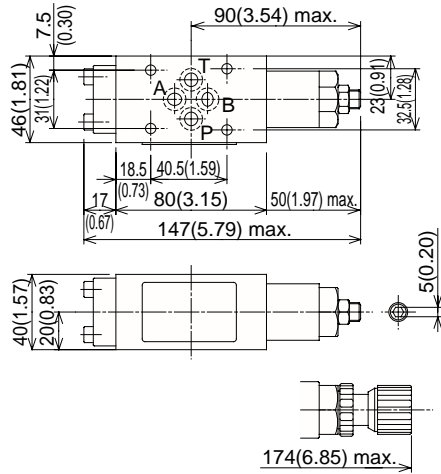

OCQ-G01-B1*-20

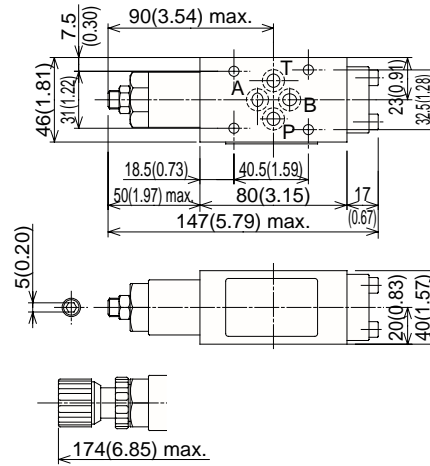

OCQ-G03-A1*-J50

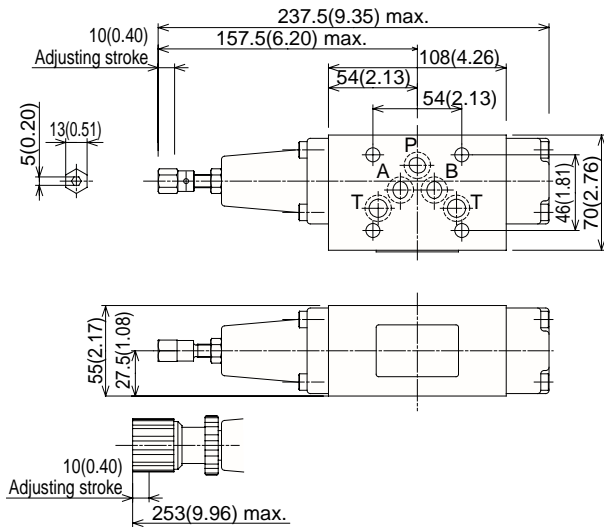

OCQ-G03-B1*-J50

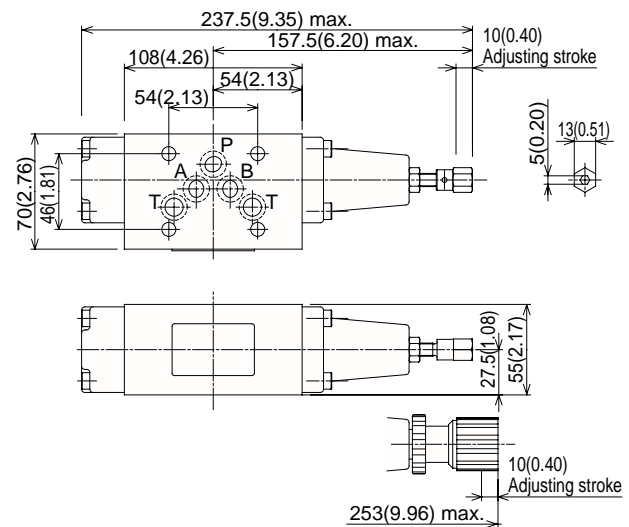

Performance Curves

Hydraulic Operating Fluid
Viscosity 32mm²/s

Pressure Loss Characteristics

OCQ-G01-A1*-20

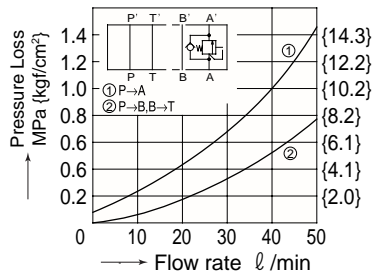

OCQ-G03-A1A-J50

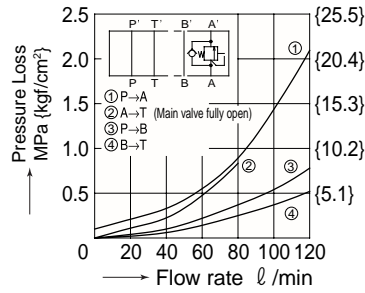

Pressure — Flow Rate Characteristics

OCQ-G01-A1*-20

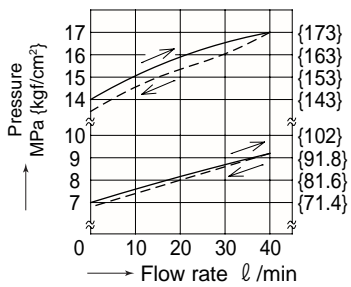

OCQ-G03-A1*-J50

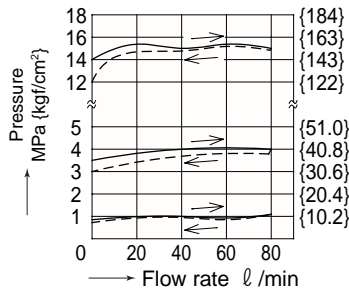

Number of Adjusting Screw Rotations — Pressure Characteristics

OCQ-G01-A1*-20

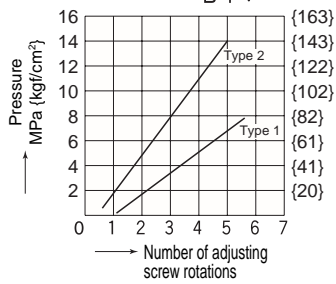

OCQ-G03-A1*-J50

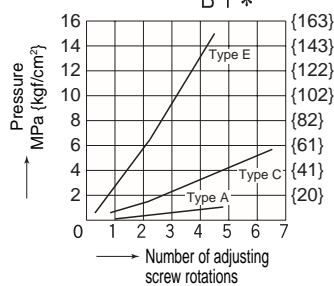

Cross-sectional Drawing

OCQ-G01-A1*-20

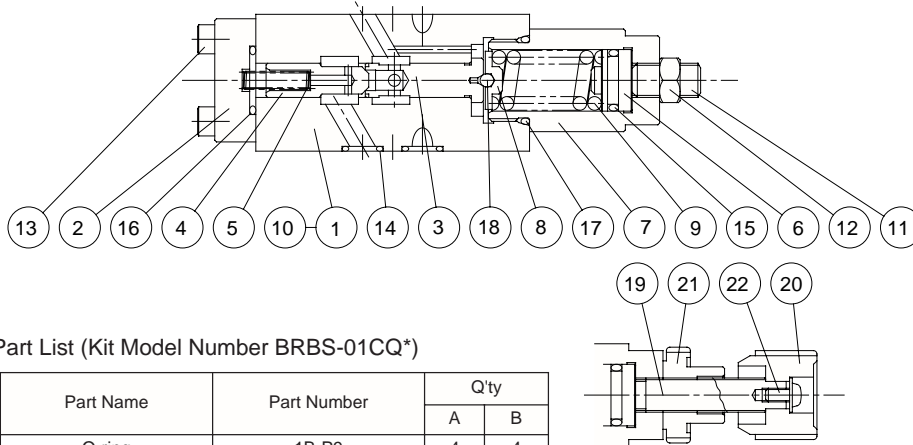

Part No.	Part Name
1	Body
2	Cover
3	Spool
4	Poppet
5	Spring
6	Plunger
7	Retainer
8	Guide
9	Spring
10	Plate
11	Screw
12	Nut
13	Screw
14	O-ring
15	O-ring
16	O-ring
17	O-ring
18	Ball
19	Screw
20	Knob
21	Nut
22	Screw

Seal Part List (Kit Model Number BRBS-01CQ*)

Part No.	Part Name	Part Number	Q'ty	
			A	B
14	O-ring	1B-P9	4	4
15	O-ring	1B-P14	1	1
16	O-ring	1B-P16	1	1
17	O-ring	1B-P22	1	1

Note) 1. O-ring 1A/B-** refers to JIS B2401-1A/B.
2. Specify A or B for the asterisk (*) in the kit model number.

OCQ-G03-A1*-J50

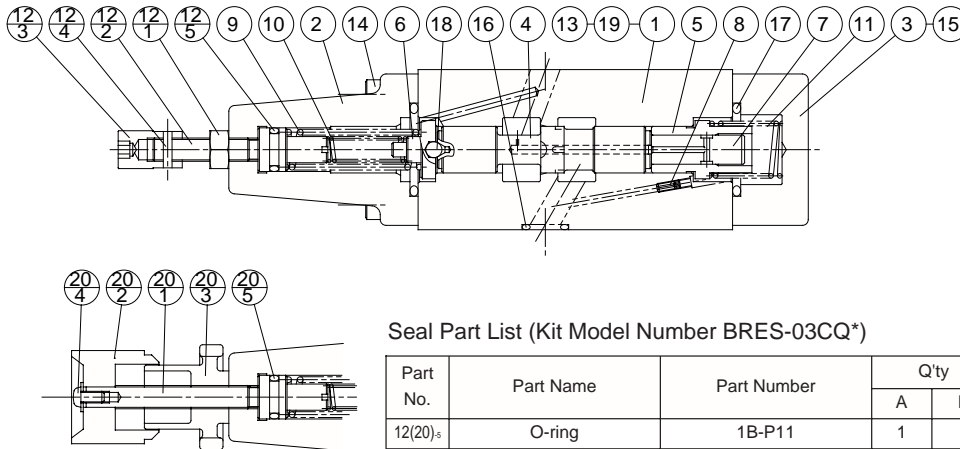

Part No.	Part Name
1	Body
2	Cover
3	Cover
4	Spool
5	Sleeve
6	Guide
7	Plunger
8	Choke
9	Spring
10	Spring
11	Spring
12	Screw kit
12.1	Screw
12.2	Nut
12.3	Nut
12.4	Pin
12.5	O-ring
13	Plate
14	Screw
15	Screw
16	O-ring
17	O-ring
18	Ball
19	Pin
20	Handle kit
20.1	Screw
20.2	Knob
20.3	Nut
20.4	Screw
20.5	O-ring

Seal Part List (Kit Model Number BRES-03CQ*)

Part No.	Part Name	Part Number	Q'ty	
			A	B
12(20) _s	O-ring	1B-P11	1	1
16	O-ring	AS568-014(Hs90)	5	5
17	O-ring	1B-P26	2	2

Note) The 10 spring is not included with pressure adjustment Type A.

Note) 1. O-ring 1A/B-** refers to JIS B2401-1A/B.
2. Specify A or B for the asterisk (*) in the kit model number.



Pressure Switch Modular Valve

13.2gpm
3571psi

Features

- ① This modular valve detects pressure changes inside the hydraulic circuit and opens and closes an electrical circuit accordingly.
- ② High precision detection, high precision circuit control, outstanding reliability.
- ③ Maximum operating pressure: 25MPa {3571psi}
- ④ Indicator light built into the DIN connector shows operational status at a glance.
- ⑤ A double type is also available for control of both port A and port B in a compact configuration.

Specifications

Model No.	Nominal Diameter (Size)	Maximum Working Pressure MPa(psi)	Maximum Flow Rate ℓ /min(gpm)	Pressure Adjustment Range MPa(psi)	Weight kg	Gasket Surface Dimensions
OW-G01-PC-R**-30 P1 P3	1/8	25{3571}	50 (13.2)	0.5 to 3.5{72 to 500}	1.8	ISO 4401-03-02-0-94
0.8 to 7{114 to 1000}						
3.5 to 21{500 to 3000}						
0.5 to 3.5{72 to 500}				1.8		
0.8 to 7{114 to 1000}						
OW-G01-AC-R**-30 A1 A3				3.5 to 21{500 to 2000}		
OW-G01-BC-R**-30 B1 B3				0.5 to 3.5{72 to 500}	1.8	ISO 4401-03-02-0-94
				0.8 to 7{114 to 1000}		
				3.5 to 21{500 to 2000}		
OW-G01-WC-R**-30 W1 W3				0.5 to 3.5{72 to 500}	2.6	
				0.8 to 7{114 to 1000}		
				3.5 to 21{500 to 2000}		

Electrical Specifications Micro Switch Manufacturer: Omron Model No. SS-5	Contact Capacitance (Resistive Load)	AC	125V	5A
			250V	3A
		DC	14V	5A
			30V	4A
	Mechanical Life	At least 1×10^7		
	Electrical Life	At least 3×10^6 (AC, 0.1A, $\cos\phi=1$)		
	Contact Resistance	30MΩ maximum (initial value)		
Insulation Resistance	At least 100MΩ			
Allowable Operating Frequency	60 times/minute (electrical)			
Operating Environment	Dust Resistance/Water Resistance Rank	JIS C0920 IP64		
	Ambient Temperature	-20°C to 70°C (non-condensation)		
	Operating Fluid	Fluid Temperature	-20°C to 70°C	Use a fluid that is within both ranges.
		Allowable Viscosity Range	15 to 300mm ² /s{cSt}	
Filtration		25μm maximum		

● Handling

- ① See the detailed explanation on the next page for information about wiring inside connectors.
- ② Contacts are normally open type only, not normally closed type.
- ③ In addition to load wiring, power supply wiring is also required to illuminate the indicator light. See the wiring diagram for more information.
- ④ If the DIN connector interferes with other valves, remove the two switch installation bolts and change the installation orientation. If interference is caused in all orientations, install an interference blanker plate on top of the connector. Contact your agent if an interference blanker plate is required.
- ⑤ Note that a special type of DIN connector is required. The DIN connector is not interchangeable with the one for the SA type solenoid valve.
- ⑥ If you cannot remove the DIN connector when wiring, remove the switch installation bolts and then remove the DIN connector. The tightening torque for the installation bolts is 5 to 7Nm {51 to 71kgf/cm}.

Understanding Model Numbers

OW - G 01 - P 1 - (K)R - D2 - 30

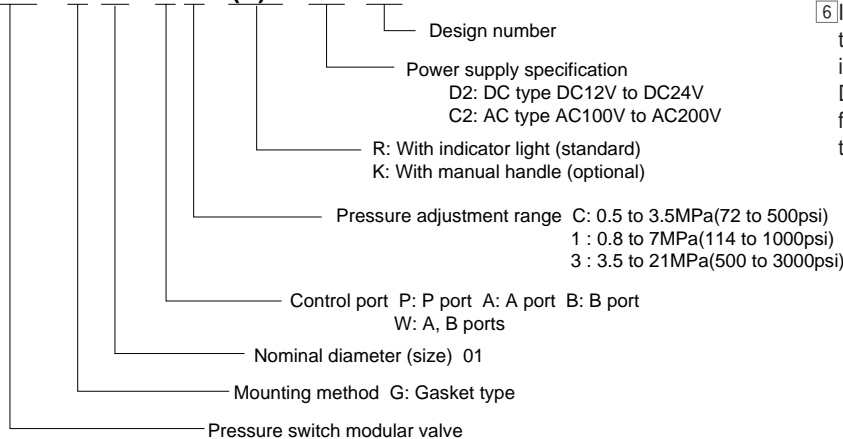

● Connectors

Model No.	Power supply specification	Wiring	Electrical Circuit Diagram
BRC41-01WD2	D2	<p>⊙When signal input device (load) remote common is plus</p> <p>OW Terminal 1 is connected to load, while Terminals 2 and 3 are connected to power (Terminal 2 to +).</p>	<p>Normal open type with indicator</p> <p>Pressure increase causes indicator to light. Circuit closed (ON)</p> <p>Pressure decrease causes indicator to go out. Circuit open (OFF)</p>
		<p>⊙When signal input device (load) common is minus</p> <p>OW Terminal 1 is connected to load, while Terminals 2 and 3 are connected to power (Terminal 2 to -).</p>	
BRC41-01WC2	C2	<p>⊙When signal input device (load) is AC</p> <p>OW Terminal 1 is connected to load, while Terminals 2 and 3 are connected to power (Terminal 2 is nonpolar).</p>	<p>Normal open type with indicator</p> <p>Pressure increase causes indicator to light. Circuit closed (ON)</p> <p>Pressure decrease causes indicator to go out. Circuit open (OFF)</p>

- Note) 1. The DIN connector wiring connector port size is PG11.
 2. The compatible cable diameter for the DIN connector is $\phi 8$ to $\phi 10$. Dust resistance and water resistance is lost for any cable outside this range.
 3. The connector can be installed in different orientations are 90-degree increments by changing the orientation of the terminal block.
 4. The connector is designed so the cover cannot be removed unless the installation screws are removed.
 5. Use M3 for round type and Y type solderless terminals.
 6. The tightening torque of M3 screws used for securing connectors and for terminals is 0.3 to 0.5Nm.

Installation Dimension Drawings

Note) Pressure is increased by clockwise (rightward) rotation of the adjusting screw, and decreased by counterclockwise (leftward) rotation.

OW-G01-P*-R-*2-30

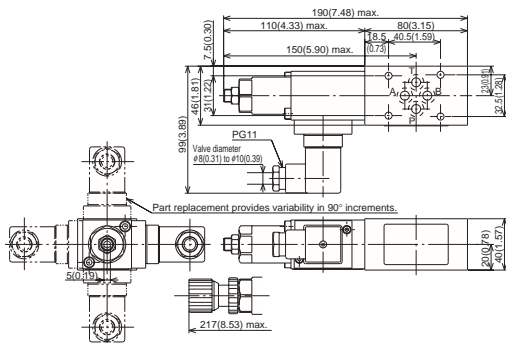

OW-G01-B*-R-*2-30

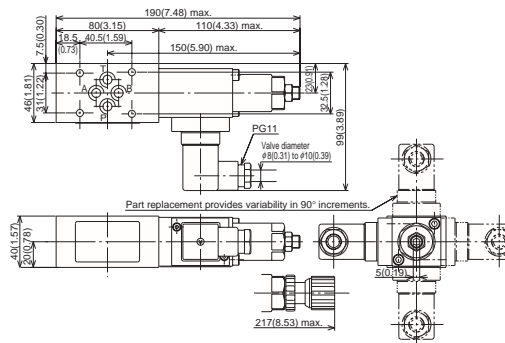

OW-G01-W*-R-*2-30

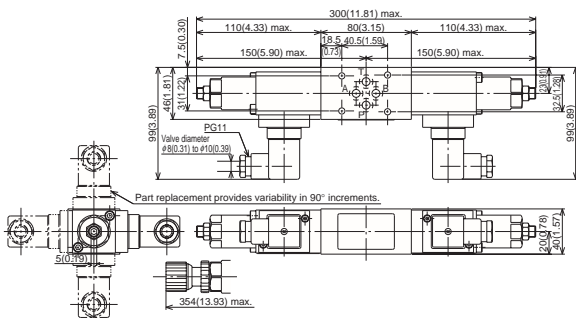

Performance Curves

Hydraulic Operating Fluid Viscosity 32mm²/s

Pressure Loss Characteristics

OW-G01-**-R**-30

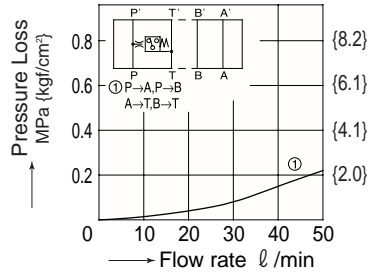

Setting Pressure — Differential Characteristics

OW-G01-^C₁-R**-30

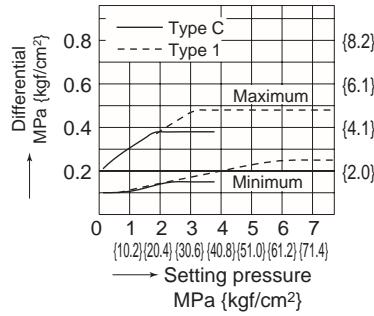

OW-G01-³-R**-30

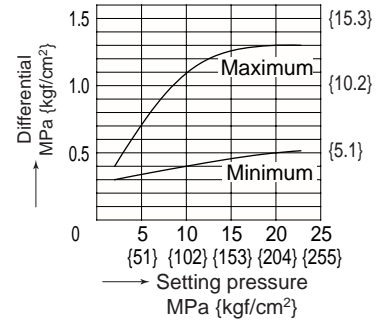

Drain Rate Characteristics

OW-G01-**-R**-30

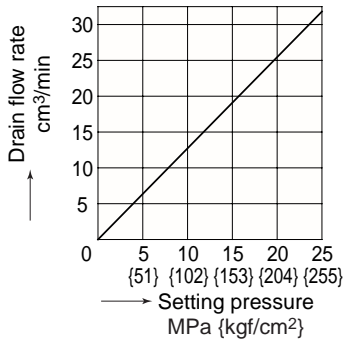

Number of Adjusting Screw Rotations — Pressure Characteristics

OW-G01-**-R**-30

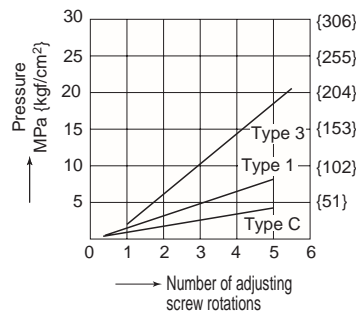

Cross-sectional Drawing

OW-G01-P*-R*-2-30

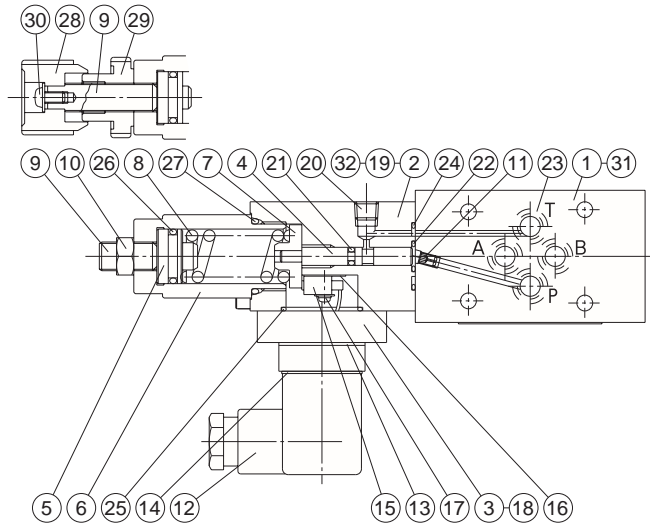

Part No.	Part Name	Part No.	Part Name
1	Body	17	Screw
2	Cover	18	Screw
3	Cover	19	Screw
4	Piston	20	Plug
5	Push rod	21	O-ring
6	Retainer	22	O-ring
7	Guide	23	O-ring
8	Spring	24	O-ring
9	Screw	25	O-ring
10	Nut	26	O-ring
11	Choke	27	O-ring
12	Connector	28	Knob
13	Gasket	29	Nut
14	Gasket	30	Screw
15	Micro switch assy	31	Plate
16	Separator	32	Plate

Seal Part List (Kit Model Number BRCS-01W*)

Part No.	Part Name	Part Number	Qty			
			P	W	A	B
21	O-ring	1A-P3	1	2	1	1
22	O-ring	AS568-011(Hs90)	1	2	1	1
23	O-ring	1B-P9	4	4	4	4
24	O-ring	AS568-019(Hs70)	1	2	1	1
25	O-ring	AS568-022(Hs70)	1	2	1	1
26	O-ring	1A-P15	1	2	1	1
27	O-ring	1B-P22	1	2	1	1

Note) Specify P, W, A, or B for the asterisk (*) in the kit model number.

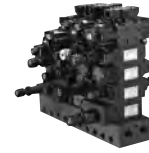

Valve Installation Bolt List

01 (nominal diameter)

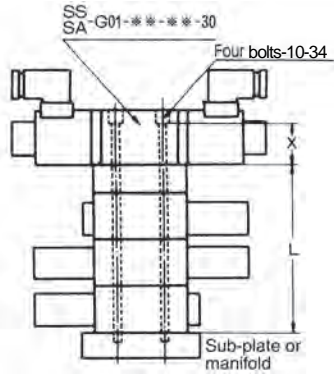

Model Number	X
SA-G01-***-**-E31	37.5(1.47)
SS-G01-***-R**-E31	

03 (nominal diameter)

SS
SA-G03-***-**-for -J21

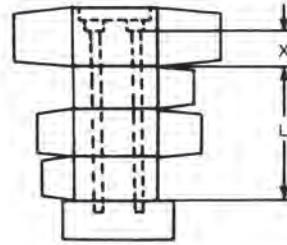

Model Number	X
SS SA-G03-***-R**-E21	60.5(2.38)

Note) 1. Model numbers indicate bolt kits for one solenoid valve.

2. Up to four modular valves can be ganged together.

3.01 Size

Modular valves at a height of $40 + 25 = 65$ mm are ganged to one level.

4. 2-pressure reducing valves at a height of 90 mm are ganged to two levels.

Type	Model Number	Dimension L	Bolt length
Hexagon Socket Head Bolt	OTH-01-70-E10	25(0.98)	70(2.75)
	85	40(1.57)	85(3.30)
	110	65(2.55)	110(4.33)
	125	80(3.14)	125(4.92)
	150	105(4.13)	150(5.90)
	165	120(4.72)	165(6.49)
	190	145(5.70)	190(7.48)
	205	160(6.25)	205(8.07)
Stat Bolt	OTD-01-80-E10	25(0.98)	80(3.14)
	95	40(1.57)	95(3.74)
	120	65(2.55)	120(4.72)
	135	80(3.14)	135(5.31)
	145	90(3.54)	145(5.70)
	160	105(4.13)	160(6.29)
	175	120(4.72)	175(6.88)
	185	130(5.11)	185(7.28)
	200	145(5.70)	200(7.87)
	210	155(6.10)	210(8.26)
	215	160(6.29)	215(8.46)
	225	170(6.69)	225(8.85)
	240	185(7.28)	240(9.44)
	250	195(7.67)	250(9.84)
	265	210(8.26)	265(10.43)
275	220(8.66)	275(10.82)	

Type	Model Number	Dimension L	Bolt length
Hexagon Socket Head Bolt	OTH-03-125-E30	55(2.16)	125(4.92)
	-180-	110(4.33)	180(7.08)
Stat Bolt	OTD-03-135-E30	55(2.16)	135(5.31)
	-190-	110(4.33)	190(7.48)
	-245-	165(6.49)	245(9.64)
	-300-	220(8.66)	300(11.81)

SS
SA-G03-***-**-for -21

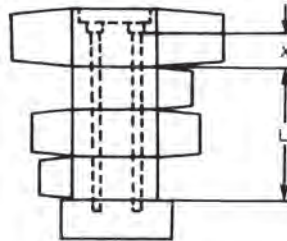

Model Number	X
SS SA-G03-***-R**-21	58(2.28)

Type	Model Number	Dimension L	Bolt length
Hexagon Socket Head Bolt	OTH-03-125-30	55(2.16)	M8 × 125
	-180-	110(4.33)	M8 × 180
Stat Bolt	OTD-03-135-30	55(2.16)	M8 × 135
	-190-	110(4.33)	M8 × 190
	-245-	165(6.49)	M8 × 245
	-300-	220(8.66)	M8 × 300

Hexagon socket head bolt

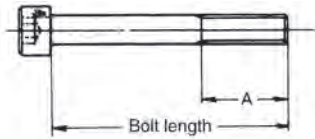

Nominal Diameter	A	Bolt Size
01	15(0.59)	M5
03	18(0.70)	M6
03	22(0.86)	M8

Dimensions other than bolt length are in accordance with JIS B 1176.

Tightening Torque

Nominal Diameter	Bolt Size	Tightening Torque N·m{kgf·cm}
01	M5/10-24UNC	5 to 7{ 51 to 71}
03	M6/1/4-20UNC	10 to 13{102 to 133}
03	M8	20 to 25{205 to 255}

Stat Bolts and Nuts

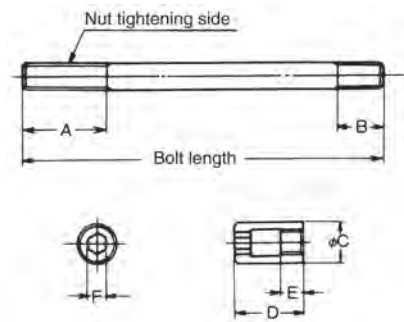

Model No.	A	B	C	D	E	F	Bolt Size
OTD-01-***-10	12(0.47)	9(0.35)	8.5(0.33)	16(0.62)	11(0.43)	4(0.15)	M5
OTD-03-***-J30	20(0.78)	10(0.39)	10(0.39)	18(0.70)	11.5(0.45)	5(0.19)	M6
OTD-03-***-30	25(0.98)	12.5(0.49)	13(0.51)	22(0.86)	15(0.59)	6(0.23)	M8
OTD-01-***-E10	12(0.47)	9(0.35)	5.5(0.21)	16(0.62)	11(0.43)	4(0.15)	10-24UNC
OTD-03-***-E30	20(0.78)	10(0.39)	10(0.39)	18(0.70)	11.5(0.45)	5(0.19)	1/4-20UNC

Stat bolts and nuts are included. The E dimension is the effective screw depth.