

INNOVATIVE SELF-CLEANING FILTERS



METALEDGE®

METALEDGE®

Innovative Self-Cleaning Filters



chewing gum base



toothpaste



recycled oil products



chocolate



paints and pigments

Metaledge® Series filters are self-cleaning filter systems designed for a wide variety of liquid process applications. The filter systems feature a cylindrical, cleanable filter element. An integral knife blade cleans the filter by wiping the trapped contaminants off the surface of the element. This self-cleaning feature eliminates the need for housings with disposable filter cartridges, thereby reducing the maintenance costs of replacement elements, change-out labor, and downtime.

Metaledge filters feature a unique brass or stainless steel filter medium, consisting of a wedge-shaped metal ribbon with formed projections. The wedge-shaped ribbon is wound edgewise on a cylindrical perforated metal core, producing a tapered flow path inward.

The height of the projections and distance between the projections determine the filtration rating. Fluid flow is from the outside to inside. Particles larger than the space between projections are stopped at the outer surface where they can be readily removed by the cleaning knife. Smaller particles wash through the tapered openings without clogging the element.

Metaledge filter media provides the greatest percentage of open area, which is several times greater than that of any other self-cleaning or wedge-wire filter media. This feature provides significantly higher flow throughput and lower pressure drop than competitive filter systems. We offer media from 25 to 500 microns.

This self-cleaning feature eliminates the need for housings with disposable filter cartridges, thereby reducing the maintenance costs of replacement elements, change-out labor, and downtime.

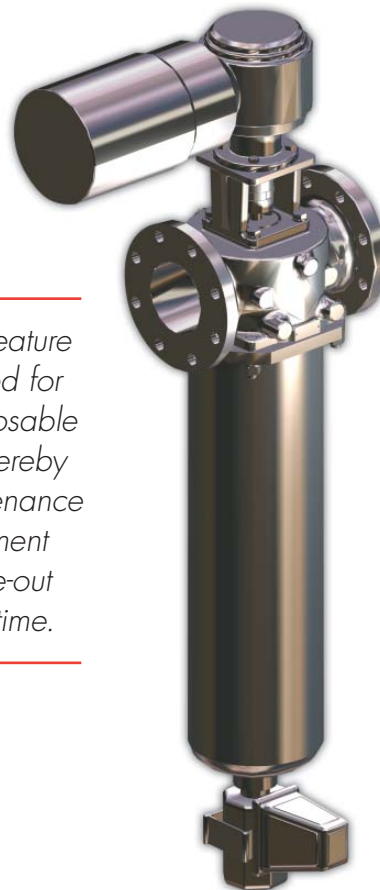

Metaledge filters come in five models depending on the desired flow rate and filtration rating. The smaller units feature a "T" handle, which the operator turns by hand to clean the element. The larger filters employ a motor and motor drive, which rotates the element against a stationary knife blade.

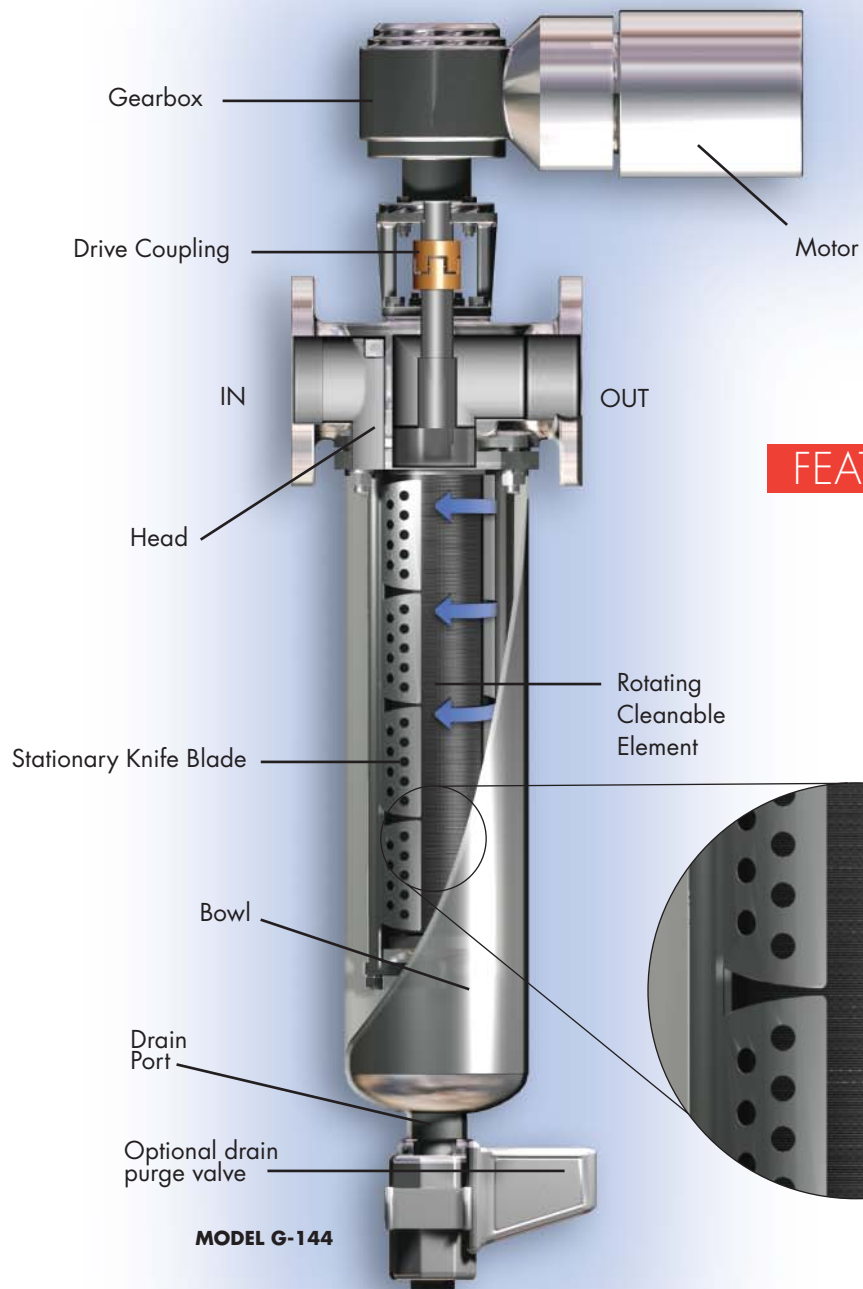

FEATURE DIAGRAM

The Metaledge® element rotates against the stationary cleaning knife, causing particles larger than the opening to be scraped off the element; smaller particles will pass through the element.

METALEDGE FILTER OPERATION



1

As fluid flows through the filter, contaminants collect on the surface of the filter element, which is sized for your application. Smaller particles pass through the media without clogging the element.

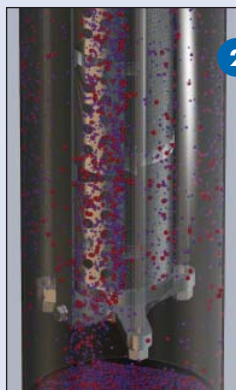

2

A cleaning knife blade passes over the filter element surface, removing the trapped contaminants, which remain in suspension or fall to the bottom of the filter bowl.

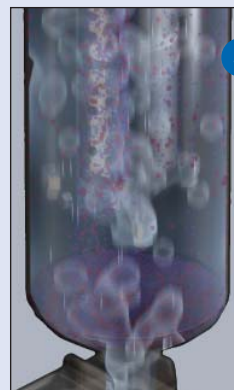

3

The filter is purged by introducing air, water, or a solvent into the system and flushing the debris out of the bottom of the filter bowl.

INNOVATIVE SELF-CLEANING FILTERS

MEDIA:

Metaledge® filter media feature a fine wedge-shaped metal ribbon wound helically on a perforated metal core. The space between each ribbon determines the micron rating of the filter. This space is precisely controlled by forming projections on the ribbon during the winding process.

The tapered flow paths in a Metaledge element prevent clogging. Particles that fail to pass through may fall off or can be scraped off the surface by the cleaning knife.

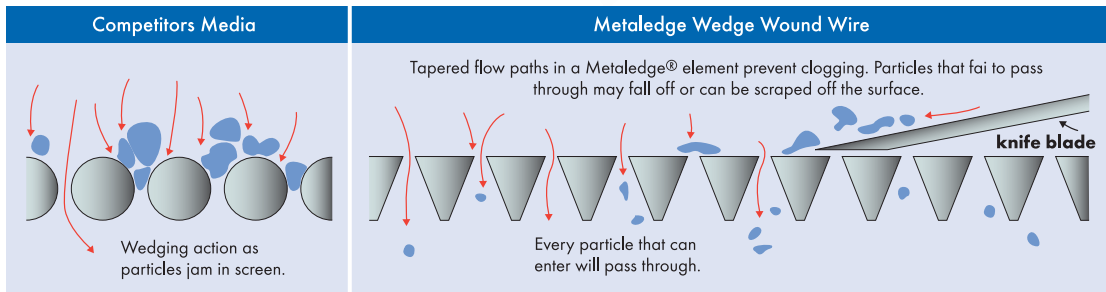
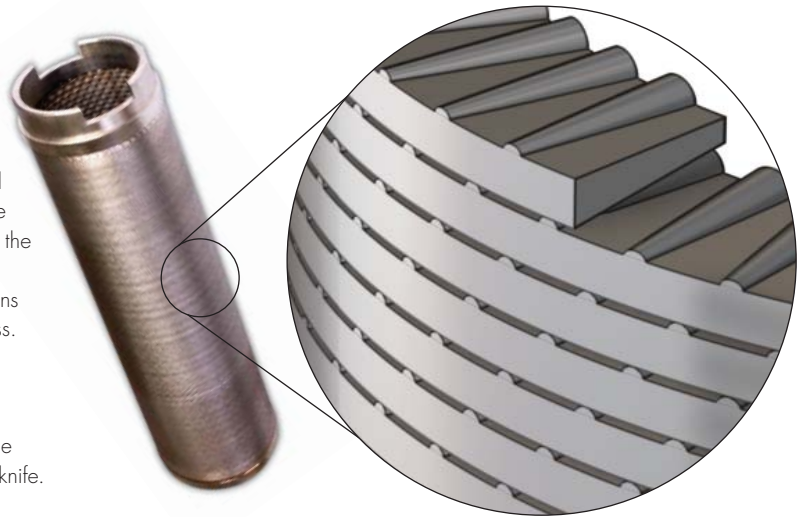

Metaledge filters provide superior surface filtration performance for a wide range of critical commercial and industrial applications. The unique wedge-shaped ribbon media provides precise filtration performance to capture contaminants, while letting smaller particles pass through without clogging the filter element.

The high porosity of the media allows Metaledge filters to process a wide range of fluids, from water to highly viscous liquids, such as syrups and toothpaste.

The self-cleaning feature of Metaledge filters assures constant filtration during long production cycles. No need to stop production in mid-stream to change out filter cartridges.

ELEMENT KITS:

Metaledge elements are extremely durable, often lasting for years. Applications requiring 24/7 service, require regular maintenance. Extended periods of operation with high viscosity and/or abrasive fluids can cause the knife and element to show wear. Replacement element kits are available and recommended for easy periodic cleaning and change-out.

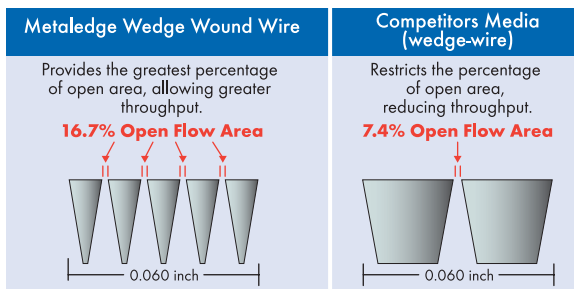

PRODUCT FEATURE	PRODUCT BENEFIT	CUSTOMER BENEFIT
WEDGE-SHAPED RIBBON MEDIA	<ul style="list-style-type: none"> Removes Unwanted Contaminant, while Allowing Smaller Particles to Pass Through without Clogging 	<ul style="list-style-type: none"> Precise Filtration Control Long Production Runs without Element Clogging
METALLIC MEDIA	<ul style="list-style-type: none"> Excellent Wear Resistance Tolerant of Abrasive Fluids High Temperature Tolerance 	<ul style="list-style-type: none"> Long Filter Element Life High Performance Filtration in Critical Applications
PROJECTIONS ON WOUND RIBBON CONTROL MICRON RATING	<ul style="list-style-type: none"> Precise Filtration Control Flexibility of Manufacturing with Minimal Inventory Stocking Requirements 	<ul style="list-style-type: none"> Lower Production Costs Lower Filter Purchase and Replacement Costs Shorter Lead Times
SELF-CLEANING ACTION OF KNIFE BLADE	<ul style="list-style-type: none"> Keeps Filter Element Clean for Continuous Filtration Rotation of the Element Assists in Blending Fluids, and Reducing the Viscosity of the Fluid 	<ul style="list-style-type: none"> Long Production Runs Without Element Clogging Lower Discharge Disposal Costs Less Effluent Loss Reduced Personnel Exposure to Production Fluids
REPLACEMENT MATCHED ELEMENT KITS	<ul style="list-style-type: none"> Element Kit is a Matched Assembly, Assuring Proper Knife Contact with the Element and the Rotation of the Element in the Spider and Adapter 	<ul style="list-style-type: none"> Quick Replacement Kit Change Out Shorter Production Down Time Precise Filtration Control Longer Element and Knife Blade Life
HIGH MEDIA POROSITY	<ul style="list-style-type: none"> Lower Differential Pressures than Competitive Media High Fluid Throughput Effective in High Viscosity Fluids 	<ul style="list-style-type: none"> Superior Product Quality Optimized Production Yields Reduced Filtration Costs
PARTICLE REMOVAL RATINGS FROM 25 TO 500 µm	<ul style="list-style-type: none"> Broad Filter Range Precise Particle Size Control - .001" - .020" 	<ul style="list-style-type: none"> Optimizes Effluent Quality, while Reducing Filtration Costs
FIVE FILTER MODELS	<ul style="list-style-type: none"> Several Port Sizes Available with Multiple Options 	<ul style="list-style-type: none"> Allows Flexibility in Flow Rates, Port Connections, Micron Selection, Temperature Tolerance, and Motor Choice



MARKET	APPLICATION
FOOD & BEVERAGE	Chewing gum base, chocolate, sauces, corn syrup, juices, candy, cooking oil, shortening
INKS AND COATINGS	Solvents, water, paint, clear coat, inks, automotive coatings, industrial coatings, lacquers, wax, varnish, adhesives
COSMETICS	Toothpaste, lotions, soaps, mouthwash, mineral oils
CHEMICAL PROCESSING	Lube oil, grease, wax, paraffin, petrochemicals, fuel oil
OIL AND GAS	Crude oil, drilling fluids, completion fluids
METAL FINISHING	Machine coolants, plating solutions, stripping solutions, hydraulic press oil
RECYCLING	Automotive oil, anti-freeze, hydraulic oil

F-190 FILTER

The F-190 is our smallest Metaledge filter assembly. Featuring a cast iron head and a steel bowl, the F-190 has a maximum operating pressure of 150 psi, and maximum flow rate of 24 gpm. This filter provides an element-cleaning knife, which is rotated around the element by turning a "T" handle.

The F-190 is designed for applications where batch processing, low flow rates, or filter portability is required. Such applications include boiler fuel oil, or truck-mounted installations.

STANDARD SPECIFICATIONS:

Housing: Cast iron head and steel bowl with enamel coating

Element & knife: brass

Packing: PTFE

Inlet/outlet ports: 3/4" NPT or 1" NPT threads

Drain port: 3/4" NPT

Maximum operating pressure: 150 psi

Maximum operating temperature: 250° F.

Case capacity: 5/8 quart - 0.15 gallon

Weight: 5 lbs.

OPTIONS:

Micron rating (see chart)

Underwriters Laboratories (UL) approved units available in select models.

Stainless steel element

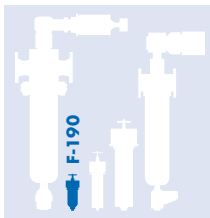
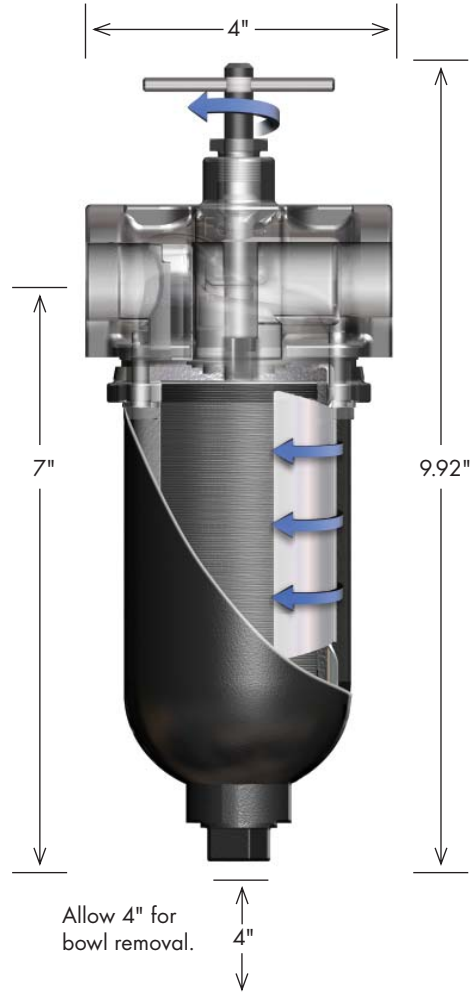

F-190 1" NPT CONNECTIONS

ELEMENT SPACING		3/4" NPT FILTER	1" NPT FILTER	ELEMENT KIT ASSY	CAPACITIES IN GPM @ CLEAN ΔP OF 3 PSI				
Inches	Micron Equivalent	Part Number	Part Number	Part Number	Water 1 cp	50 cp	100 cp	150 cp	200 cp
.001	25	6600060-01	6600090-01	6600110	8	5	3	3	2
.0015	37.5	6600061-01	6600091-01	6600111	10	7	5	4	3
.002	50	6600062-01	6600092-01	6600112	13	9	6	5	4
.003	75	6600063-01	6600093-01	6600113	17	11	8	6	5
.005	125	6600064-01	6600094-01	6600114	22	15	11	8	7
.007	175	6600065-01	6600095-01	6600115	23	17	12	9	8
.008	200	6600066-01	6600096-01	6600116	24	17	13	10	8
.010	250	6600067-01	6600097-01	6600117	24	17	13	10	8
.015	375	6600068-01	6600098-01	6600118	24	17	13	10	8
.020	500	6600069-01	6600099-01	6600119	24	17	13	10	8

Element Kit Includes: Element, Knife Assembly, Cotter Pin, Washer, Packing, and Head/Bowl Gasket.

F-140 FILTER

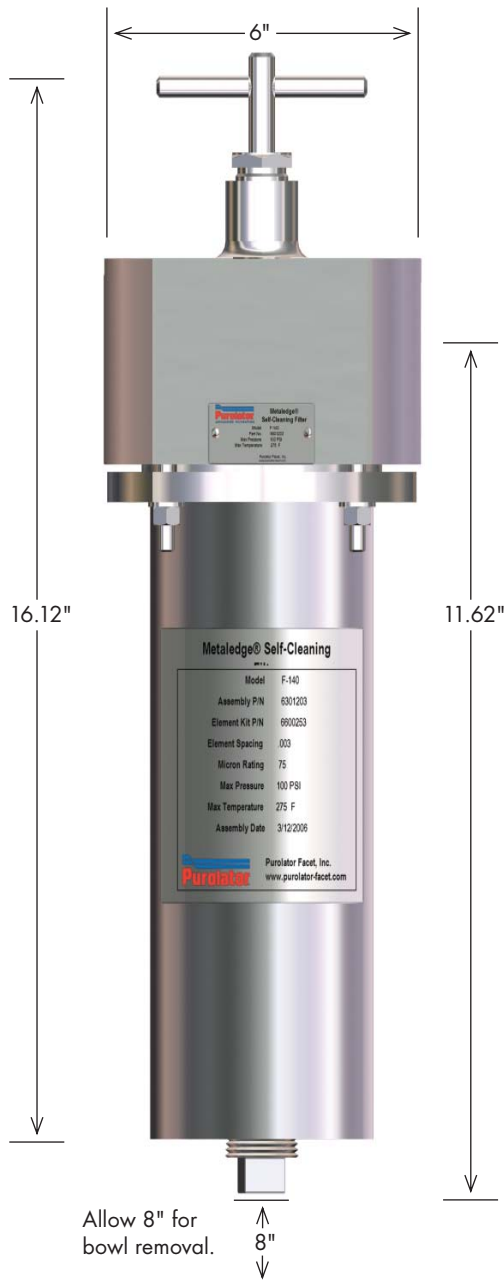

The F-140 is a medium-size Metaledge filter assembly. Made from a stainless steel head and bowl, the F-140 has a maximum operating pressure of 100 psi, and maximum flow rate of 48 gpm. This filter features a "T" handle, which the operator turns by hand to clean the element. This action causes the filter element to rotate against a stationary cleaning knife. This scraping action removes the contaminant from the surface of the filter element.

The F-140 is designed for applications where batch processing, low flow rates, or filter portability is required. Such applications include toothpaste, paints and coatings, and adhesive processing installations.

STANDARD SPECIFICATIONS:

Head: Machined Stainless Steel

Bowl: Stainless Steel

Element & knife: Stainless Steel

Packing: PTFE

Inlet/outlet ports: 1½" NPT threads

Drain port: 1" NPT threads

Maximum operating pressure: 100 psi

Maximum operating temperature: 275° F.

Case capacity: 0.6 gallon

Weight: 16 lbs.

OPTIONS:

Micron rating (see chart)

Aluminum head/steel bowl

Manual only

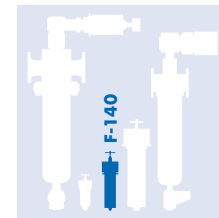

F-140 1½" NPT CONNECTIONS

ELEMENT SPACING		FILTER Part Number	ELEMENT Part Number	CAPACITIES IN GPM @ CLEAN ΔP OF 3PSI VISCOSITIES IN CENTIPOISE				
Inches	Micron Equivalent			Water 1 cp	50 cp	100 cp	150 cp	200 cp
.001	25	6658559	6600250	10	8	6	4	3
.0015	37.5	6658560	6600251	20	13	9	7	5
.002	50	6658561	6600252	25	16	11	8	6
.003	75	6658562	6600253	33	22	16	12	9
.005	125	6658563	6600254	43	30	22	16	13
.007	175	6658564	6600255	47	33	24	18	15
.008	200	6658565	6600256	48	34	25	19	15
.010	250	6658566	6600257	48	34	25	19	15
.015	375	6658567	6600258	48	34	25	19	15
.020	500	6658568	6600259	48	34	25	19	15

F-141 FILTER

The F-141 is a medium size Metaledge filter assembly. With a stainless steel head and bowl, the F-140 has a maximum operating pressure of 150 psi, and maximum flow rate of 82 gpm. This filter features a motor-driven element, which can be programmed to rotate continuously against a stationary cleaning knife, or programmed to periodically rotate based on time or differential pressure. A "T" handle for manual operation is available as an option.

The F-141 is designed for medium flow applications where intermittent or continuous filter cleaning is required. Such applications include toothpaste, inks and coatings, and lube oil processing applications.

STANDARD SPECIFICATIONS:

Head: Stainless steel

Bowl: Stainless steel

Element & knife: Stainless Steel

Packing: PTFE

Inlet/outlet ports: 2" NPT threads

Drain port: 2" NPT threads

Maximum operating pressure: 150 psi

Maximum operating temperature: 275° F.

Case capacity: 1.5 gallons

Weight (approximate): without motor: 40 lbs.
with motor: 100 lbs.

OPTIONS:

Micron rating (see chart)

Manual drive with "T" handle (unit shown)

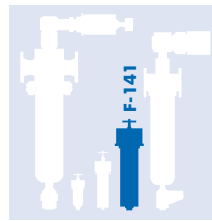

Filter shown is a manual unit, standard unit is motor driven. See illustration for G-144 for motor installation.

Allow 5" to remove element. Recommended clearance to remove bowl completely away from filter is 16".

F-141 2" NPT CONNECTIONS

ELEMENT SPACING		MOTOR DRIVEN FILTER Part Number	ELEMENT KIT Part Number	CAPACITIES IN GPM @ CLEAN ΔP OF 3PSI VISCOSITIES IN CENTIPOISE				
Inches	Micron Equivalent			Water 1 cp	50 cp	100 cp	150 cp	200 cp
.001	25	6658890	6600590	24	16	11	8	7
.0015	37.5	6658891	6600591	34	23	16	12	9
.002	50	6658892	6600592	43	29	20	15	12
.003	75	6658893	6600593	57	39	28	21	16
.005	125	6658894	6600594	74	52	37	28	22
.007	175	6658895	6600595	79	56	40	31	24
.008	200	6658896	6600596	82	58	43	33	26
.010	250	6658897	6600597	82	58	43	33	26
.015	375	6658898	6600598	82	58	43	33	26
.020	500	6658899	6600599	82	58	43	33	26

ORDERING CODE	P/N	H.P.	PHASE	VOLTS	CURRENTS	CYCLE	MOTOR TYPE
-99	6357700	1/3	3	230/460	AC	60	TEFC
-01	6357701	1/3	3	230/460	AC	50/60	EPNV
-02	6357702	1/3	3	115/230	AC	60	TEFC
-03	6357703	1/3	1	115/230	AC	50/60	EPNV
-13	6357713	1/3	3	190/380	AC	50	EPNV
-14	6357714	1/4	3	190/380	AC	50	TEFC
-36	6357736	1/3	3	208/415	AC	50	EPNV

To specify the complete F-141 filter part number, add the two-digit motor ordering code to the end of the filter part number. For example: 6658890-01

TEFC = Totally Enclosed Fan Cooled

EPNV = Explosion Proof Non-Ventilated

Element kit includes: Element, Knife, Adapter, Spider, Support Rods (3), Thrust Washer and Bushing, Head/Bowl Gasket.

G-144 FILTER

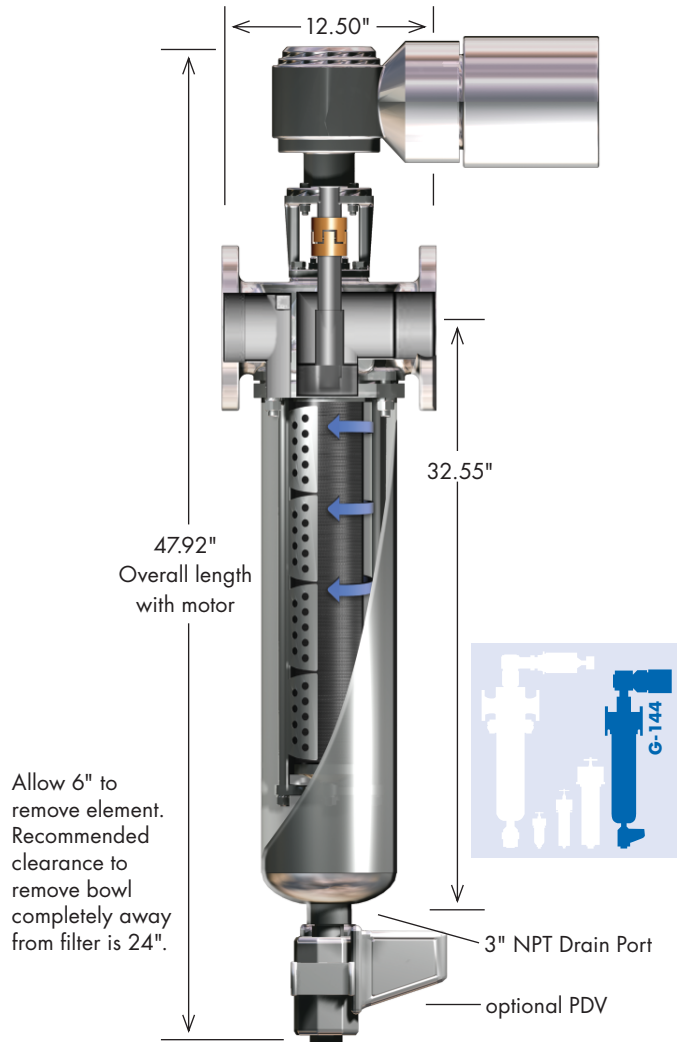

The G-144 is our largest Metaledge filter model. Made from a stainless steel head casting and a stainless steel bowl, the G-144 has a maximum operating pressure of 125 psi, and maximum flow rate of 291 gpm. This filter features a motor driven element which can be programmed to rotate continuously against a stationary cleaning knife, or can be programmed to periodically rotate based on time or differential pressure.

The G-144 is designed for high flow applications where continuous filter cleaning is required. Such applications include toothpaste, paints and coatings, and lube oil, or grease processing installations.

STANDARD SPECIFICATIONS:

Head: Stainless steel casting
Bowl: Stainless steel
Element & knife: Stainless Steel
Inlet/outlet ports: 4" 150# ASA flanges
Drain port: 3.00" - 8 NPT
Maximum operating pressure: 125 psi
Maximum operating temperature: 275° F.
Case capacity: 6 gallons
Weight (approximate): 170 lbs.

OPTIONS:

Micron rating (see chart)
 Motor options: (see chart)
 Drain purge valve
 Two knife blades positioned 180° apart
 Steam jacket bowl
 Hyblar (wear resistant plastic) knife blades

G-144 4" FLANGES

ELEMENT SPACING		FILTER Part Number	ELEMENT KIT Part Number	CAPACITIES IN GPM @ CLEAN ΔP OF 3PSI VISCOSITIES IN CENTIPOISE				
Inches	Micron Equivalent			Water 1 cp	50 cp	100 cp	150 cp	200 cp
.001	25	6302800	6300600	136	74	47	33	25
.0015	37.5	6302801	6300601	148	88	61	45	36
.002	50	6302802	6300602	162	109	76	57	45
.003	75	6302803	6300603	213	145	103	78	61
.005	125	6302804	6300604	267	191	140	108	86
.007	175	6302805	6300605	287	206	152	117	94
.008	200	6302806	6300606	291	212	158	122	98
.010	250	6302807	6300607	291	212	158	122	98
.015	375	6302808	6300608	291	212	158	122	98
.020	500	6302809	6300609	291	212	158	122	98

ORDERING CODE	P/N	MOTOR DESCRIPTION					
		H.P.	PHASE	VOLTS	CURRENTS	CYCLE	MOTOR TYPE
-99	6357700	1/3	3	230/460	AC	60	TEFC
-01	6357701	1/3	3	230/460	AC	50/60	EPNV
-02	6357702	1/3	3	115/230	AC	60	TEFC
-03	6357703	1/3	1	115/230	AC	50/60	EPNV
-13	6357713	1/3	3	190/380	AC	50	EPNV
-14	6357714	1/4	3	190/380	AC	50	TEFC
-36	6357736	1/3	3	208/415	AC	50	EPNV

To specify the complete G-144 filter part number, add the two-digit motor ordering code to the end of the filter part number. For example: 6302804-01
 TEFC = Totally Enclosed Fan Cooled
 EPNV = Explosion Proof Non-Ventilated

Element kit includes: Element, Knife, Adapter, Spider, Support Rods (3), Thrust Washer and Bushing, Head/Bowl Gasket.

F-144 FILTER

The F-144 is a fabricated (welded) version of our largest Metaledge filter model. Made from standard stainless steel pressure vessel materials, it has a maximum operating pressure of 150 psi, and maximum flow rate of 291 gpm. The housing is designed and fabricated per ASME section VIII Division 1 code. This filter features a motor driven element which can be programmed to rotate continuously against a stationary cleaning knife, or programmed to periodically rotate based on time or differential pressure.

The F-144 is designed for high flow applications where continuous filter cleaning is required. Such applications include toothpaste, paints and coatings, and chocolate.

STANDARD SPECIFICATIONS:

Head: Stainless steel weldment

Bowl: Stainless steel

Element & knife: Stainless Steel

packing: PTFE

Inlet/outlet ports: 4.00" NPS class 150# flanges per ASME B16.5

Drain port: 3" NPT

Maximum operating pressure: 150 psi

Maximum operating temperature: 250° F.

Case capacity: 6 gallons

Weight (approximate): with motor: 170 lbs.

OPTIONS:

Micron rating (see chart), Motor options: (see chart)

Drain purge valve, Steam jacket

ASME code stamp available, special order

Two knife blades positioned 180° apart

Hyblar (wear resistant plastic) knife blades

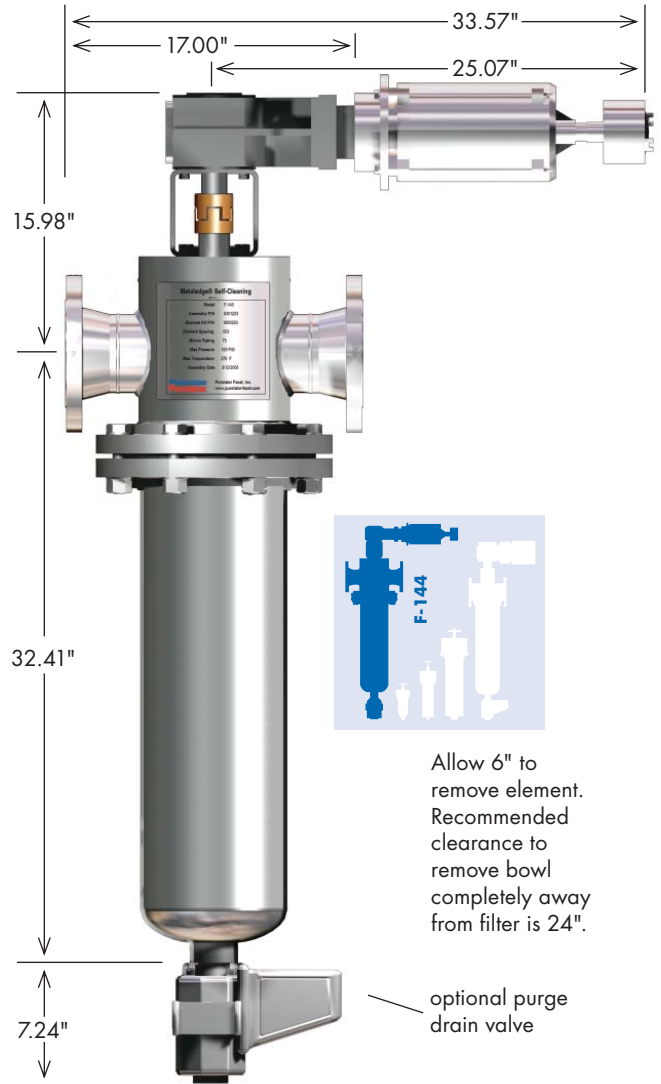

F-144 4" FLANGES

ELEMENT SPACING		FILTER Part Number	ELEMENT KIT Part Number	CAPACITIES IN GPM @ CLEAN ΔP OF 3PSI VISCOSITIES IN CENTIPOISE				
Inches	Micron Equivalent			Water 1 cp	50 cp	100 cp	150 cp	200 cp
.001	25	6601950	6600600	136	74	47	33	25
.0015	37.5	6601951	6600601	148	88	61	45	36
.002	50	6601952	6600602	162	109	76	57	45
.003	75	6601953	6600603	213	145	103	78	61
.005	125	6601954	6600604	267	191	140	108	86
.007	175	6601955	6600605	287	206	152	117	94
.008	200	6601956	6600606	291	212	158	122	98
.010	250	6601957	6600607	291	212	158	122	98
.015	375	6601958	6600608	291	212	158	122	98
.020	500	6601959	6600609	291	212	158	122	98

ORDERING CODE	P/N	H.P.	MOTOR DESCRIPTION					MOTOR TYPE
			PHASE	VOLTS	CURRENTS	CYCLE		
-99	6357700	1/3	3	230/460	AC	60	TEFC	
-01	6357701	1/3	3	230/460	AC	50/60	EPNV	
-02	6357702	1/3	3	115/230	AC	60	TEFC	
-03	6357703	1/3	1	115/230	AC	50/60	EPNV	
-13	6357713	1/3	3	190/380	AC	50	EPNV	
-14	6357714	1/4	3	190/380	AC	50	TEFC	
-36	6357736	1/3	3	208/415	AC	50	EPNV	

To specify the complete F-144 filter part number, add the two-digit motor ordering code to the end of the filter part number. For example: 6601950-01
TEFC = Totally Enclosed Fan Cooled
EPNV = Explosion Proof Non-Ventilated

Element kit includes: Element, Knife, Adapter, Spider, Support Rods (3), Thrust Washer and Bushing, Head/Bowl Gasket.

COMPARISON CHARTS

Model	Ports	Flow Rate of Water in GPM	Operating Pressure	Material of Construction	Manual/Motor Drive
F-190	3/4" or 1" NPT Threads	8-24	150 psi at 275° F	Housing—steel Element & Knife—Brass	Manual Only—Knife blade rotates around a stationary element
F-140	1 1/2" NPT threads	10-48	100 psi at 275° F	Head—machined aluminum Bowl—Stainless steel Element & Knife—SS	Manual Only—Element rotates against a stationary knife blade
F-141	2" NPT Threads	24-82	150 psi at 275° F	All stainless steel	Manual or Motor Driven construction—Element rotates against a stationary knife blade
G-144	4" 150# ASA Flanges	136-291	125 psi at 275° F	All stainless steel	Motor Driven Only—Element rotates against a stationary knife blade
F-144	4" 150# NPS Class Flanges	136-291	150 psi at 250° F	All stainless steel Fabricated vessel	Motor Driven Only—Element rotates against a stationary knife blade

METAEDGE FILTERS: SIZE RELATIONSHIP CHART

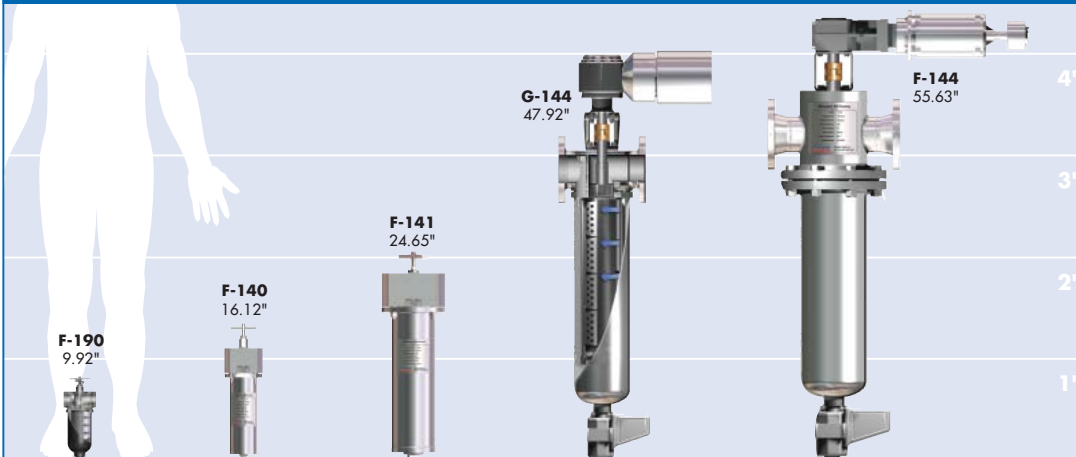

INNOVATIVE SELF-CLEANING FILTERS



Purolator Facet, Inc. a CLARCOR Company | Made in USA
8439 Triad Drive | Greensboro, NC 27409
Tel: 800.852.4449 or 336.668.4444 | Fax: 336.668.4452
Email: info@purolator-facet.com | Web: www.purolator-facet.com

