

LUCIFER®

***EPP3 High Flow
Series G1, G2
Electropneumatic
pressure regulator***
with integrated electronic control

*Catalogue 8679/GB
February 2000*



INTRODUCTION

The product

A range of electropneumatic pressure regulators G1 and G2 which, by means of an integrated electronic control system and pulse width modulated solenoid valves, controls the output pressure proportionally to an analog electrical signal. High precision is achieved by means of an internal feed-back loop through an integrated pressure sensor.

Applications

Pressure control independent of flow in electropneumatic control systems for the following main segments:

- Plastic processing machinery (plastic moulding, plastic blowing)
- Sand blasting
- Metal press balancing

Benefits

- Simplification of control systems by reducing the number of components
- More flexibility of the controls
- Increase of the productivity (performances, quality, reliability)
- Increase in safety
- Reduce installation cost
- Reduce maintenance

THE REGULATOR EPP3 - DESCRIPTION OF OPERATION

The EPP3 - High Flow Series is a family of electrically remote-controlled pneumatic pressure regulators.

The EPP3 regulator allows regulation of the outlet pressure proportionally to an electrical control signal. It comprises an integrated closed loop electronic control and two pulse width modulated 2-way solenoid valves. The pressure sensor measures the outlet pressure and provides a feed-back signal to the differential amplifier.

Any difference between the control signal and the feedback signal is converted to a digital signal to energize the coil of one or the other 2-way valves. This is then followed by an immediate soft correction of the outlet pressure without overshoot.

The analog control signal can be a voltage (0-10V) or a current (4 - 20 mA). The inlet of the "filling valve" is connected directly to the main inlet P of the regulator. When energized this valve will increase the pressure at the outlet A.

When the "exhaust valve" is energized the pressure at the outlet A will decrease. The pressure will be exhausted through a discharge slot located between the cover and the body and directly fed to the atmosphere without silencer. The exhaust of the main regulated pressure will be made through the exhaust R.

The solenoid valves assure the filling or emptying of the servo-chamber in order to increase or decrease the pressure at the outlet of the regulator. In rest position of the valves, all ports are blocked.

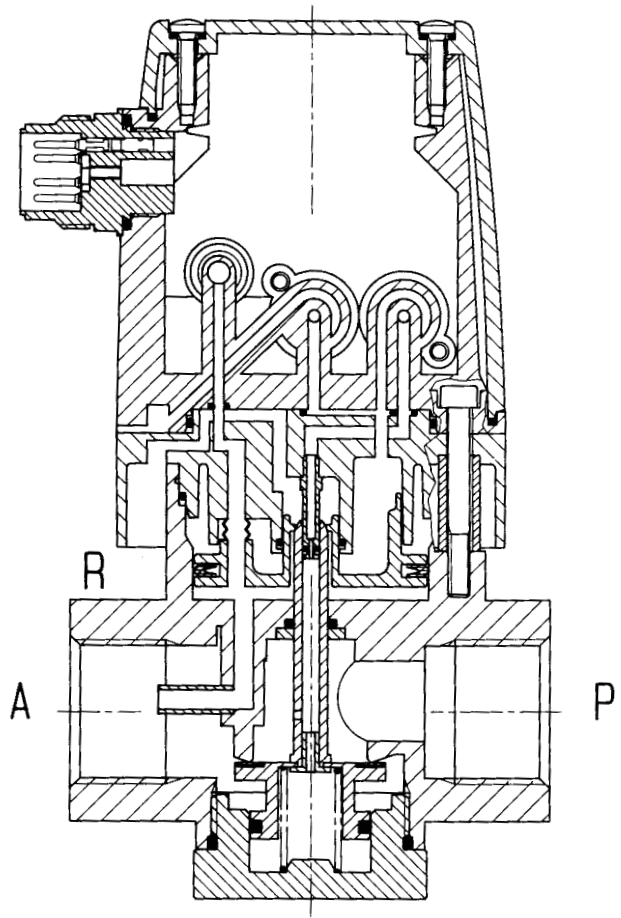

TECHNICAL DATA

Fluid:	Lubricated or non lubricated air and neutral gases (recommended filtration: 25-50 μ).	
Temperature range:	ambient 0 to 50° C fluid 0 to 50° C	
Inlet pressure range:	1 to 12 bar (the inlet pressure must always be at least 1 bar above the regulated pressure).	
Outlet pressure range:	0.2 to 10 bar	
Hysteresis:	\approx 100 mbar (Factory set up)	
Linearity:	1% f.s.o.	
Air consumption at constant control signal:	0	
Supply voltage:	24 V DC \pm 15 % (Max. ripple 1 V)	
Power consumption:	max. 6 W with 24 V DC and constant changes of the control signal < 1 W without change of control signal.	
Control signal:	analog 0-10 V analog 4-20 mA	Impedance: 10 k Ω Impedance: 0.5 k Ω
Outlet sensor signal:	<p>A) proportional pressure outlet signal 0-10 V from integrated sensor (recommended load resistance min. 10 kΩ)</p> <p>B) proportional pressure outlet signal 4-20 mA from integrated sensor (recommended load resistance 0.5 kΩ)</p> <p>C) "Alarm" output signal 0/24 V with adjustable triggering level. (Difference between control signal and sensor pressure signal) (Imax. = 40 mA)</p> <p>- factory set up: diff. signal = \pm 0.8 V to \pm 1 V</p> <p>- possible set up: diff. signal = \pm 0.1 V to \pm 5 V</p> <p>To neutralize the alarm output signal during the control signal changes, the use of a synchronized time lag relay is required.</p>	
Safety position:	In case of control failure or if it is less than 1% of its full scale value, the regulated pressure drops automatically to 0 bar (atmospheric pressure). In case of voltage supply failure, the regulated pressure will be kept constant (with eventual discrepancy due to loss of pressure in the servo-chamber).	
Electrical connection:	Through DIN 43651 circular plug-in connector (6 P + E).	
Life expectancy:	> 20 Mio changes of control signal steps.	
Mounting position:	Indifferent (recommended position: upright; electronic part on top).	
Resistance to vibrations:	30 g in all directions.	
Degree of protection:	IP 65.	
Assembly:	Silicone free.	
Electromagnetic compatibility:	In accordance with IEC 801-4 part 4 standards.	
Installation and setting instructions:	See publication MI-9202 and appendix supplied with the product.	

HYSTERESIS DIAGRAM

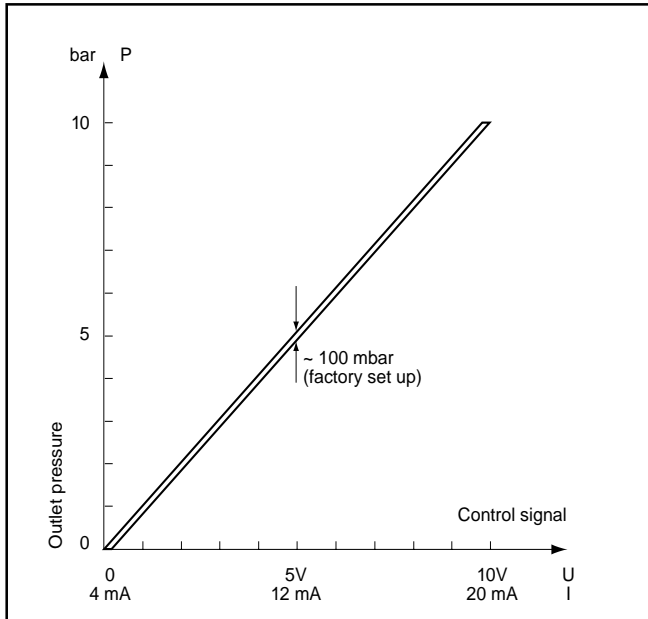

MAINTENANCE KIT

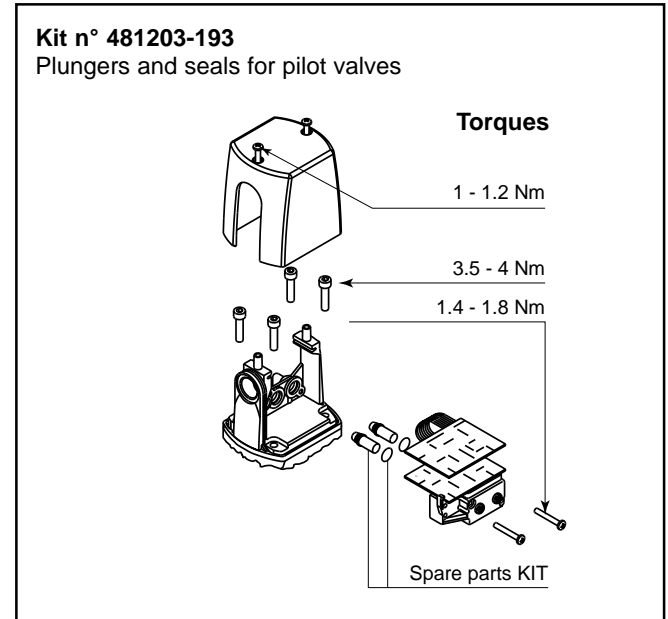

EPP3 - BLOCK DIAGRAMS

with integrated pressure sensor and output signal module

Through a differential amplifier, the electronic control unit receives both the control signal (set pressure) and the feedback signal from the sensor (outlet pressure). Any difference between the two amplifier inputs results in a corresponding output which drives the appropriate 2-way pulse width modulated solenoid valve. The closing and opening of these pilots corrects the outlet pressure. An integrated output signal module allows the utilization of voltage- and current output signals (0-10 V, 4-20 mA) proportionally to the outlet pressure, or a voltage output signal and an alarm output signal 0/24 V DC.

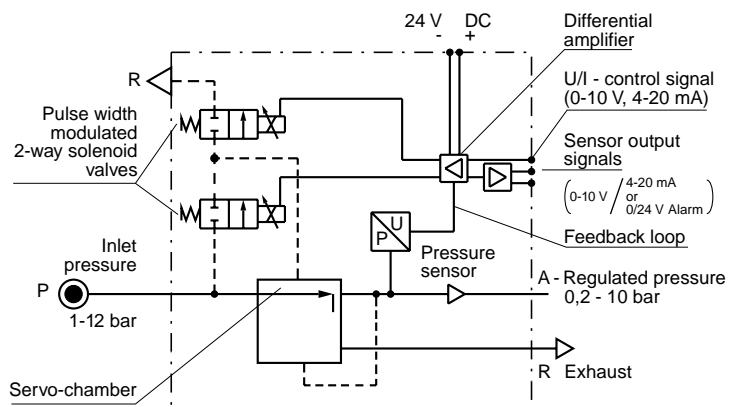

FLOW DATA - OUTLET PRESSURE IN FUNCTION OF FLOW AT CONSTANT CONTROL SIGNAL (P1 = 7 bar)

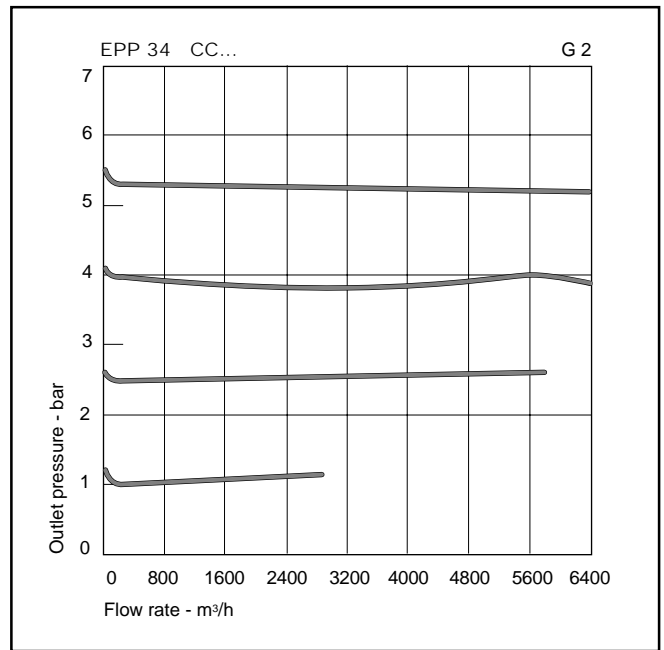
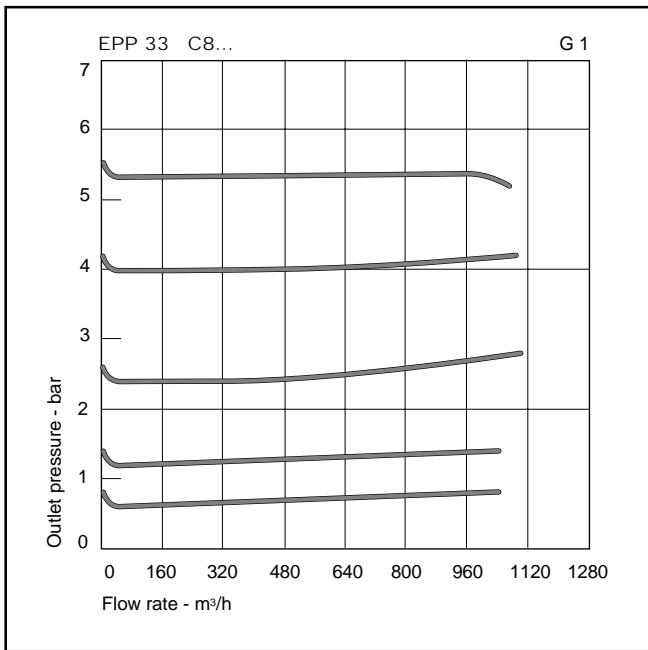

DIMENSIONS

EPP33 C8 ...

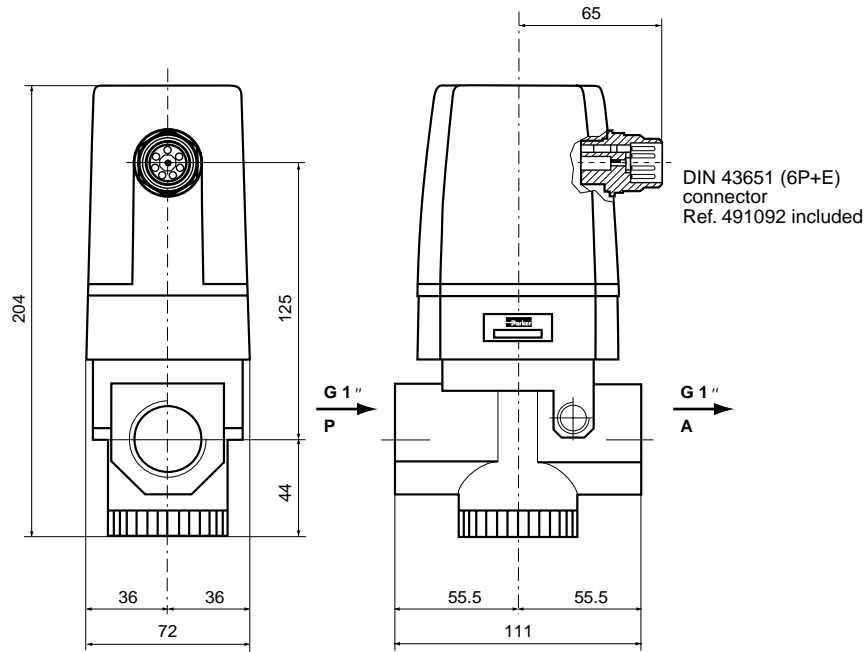

**EPP34 CB ...
EPP34 CC ...**

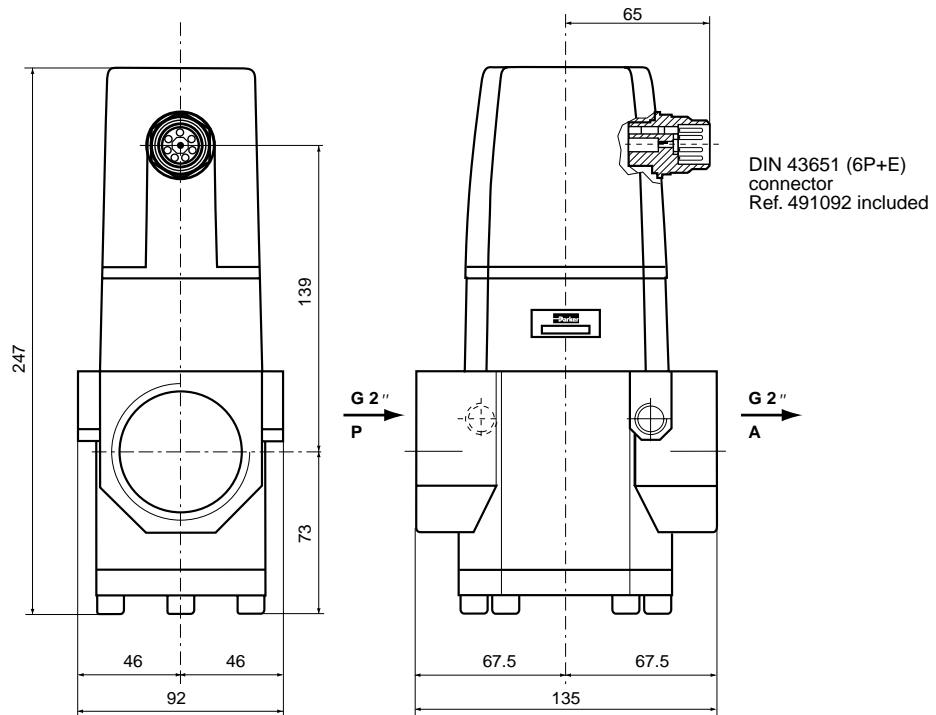

DESIGNATION CODE

EPP3 3 C 81 U 600 10 ...

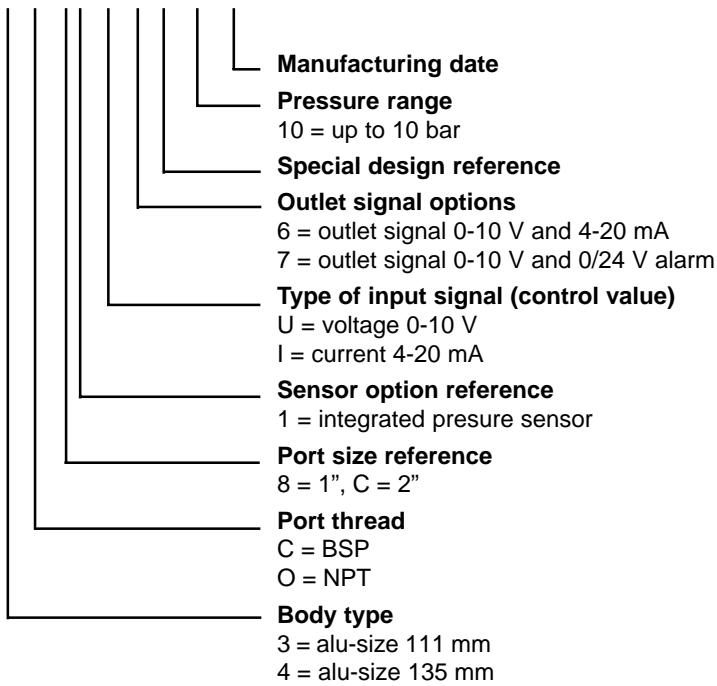

SUMMARY OF TYPES

	Connection G	With integrated pressure sensor	Outlet signal options		Electrical connection DIN 43651 connector
			0 - 10 V 4 - 20 mA	0 - 10 V 0/24 V alarm	
EPP3 3C8 1U/I 600 10	1	•	•		•
1U/I 700 10	1	•		•	•
EPP3 4CC 1U/I 600 10	2	•	•		•
1U/I 700 10	2	•		•	•



Parker Lucifer SA
16, Ch. du Faubourg de Cruseilles
CH-1227 Carouge-Geneva
Switzerland
Tel. +41 22 3077 111
Fax +41 22 3077 110

Catalogue 8679/GB
February 2000