



F/HF/SSF



FIXED TUBE BUNDLE HEAT EXCHANGERS

Fixed Tube Bundle Heat Exchangers

Young Touchstone fixed tube bundle heat exchangers are available in two basic types, copper base alloy and stainless steel construction, to cover virtually any application. These heat exchangers are capable of satisfying various cooling requirements – from simple cooling of oil or water to the more complex cooling and heating requirements of exotic liquids or gases.

One of the many advantages Young Touchstone heat exchangers offer is economy, both in initial cost and in operation. Savings are possible because stock models are constructed of standard components. Economy is

possible because their multi-pass, close-packed construction permits a reduction in cooling liquid requirements. In addition, the tube side is readily accessible for cleaning and inspection.

The use of copper tubing in F and HF exchangers provides for some resistance to many, mildly corrosive fluids; however the use of 90-10 copper nickel tubes is recommended for improved resistance to corrosion from salt or brackish waters.

Bonnets provide smooth flow with minimum impact on the tube ends and tube sheets.

F HEAT EXCHANGER

F fixed tube bundle heat exchangers are nonferrous except the 10 SHELL DIAMETER CODE units which have steel shells. The tubes are high temperature bonded into the headers, allowing minimum tube pitch and permitting a greater number of tubes, resulting in maximum cooling surface area per unit volume of space.

Applications range from cooling of engine jacket water and lube oil, torque converter fluid and hydraulic fluid, to the heating or cooling of process fluids.

HF (high pressure) HEAT EXCHANGER

HF fixed tube bundle heat exchangers are specially designed for higher shell pressures. The HF line is identical to the F dimensionally, however, due to construction differences, operating pressures of **250 psi** 1725 kPa on the shell side are possible.

HF exchangers are used with hydraulic fluids, process fluids and other similar applications where high pressures are encountered.

SSF (stainless steel) HEAT EXCHANGER

The shell and tube passages of SSF fixed tube bundle heat exchangers are constructed mainly of 316 stainless steel (18% chromium, 14% nickel, 3% molybdenum) for corrosion resistance and strength. They are used for heating and cooling of liquids and gases where a high degree of corrosion is encountered. Tubes are rolled into tube sheets by an electronically controlled process, making high-strength, leakproof joints.

The corrosion resistant properties of SSF fixed tube bundle heat exchangers make them suitable for applications in the chemical, food, pharmaceutical, refining and petro-chemical industries.

Temperature control is provided on this packaged hydraulic power system by a Model HF-806-ER-4P heat exchanger.

Fig. 4

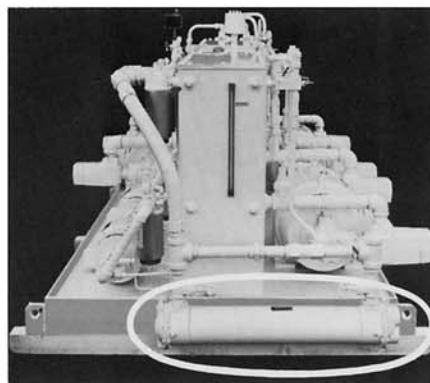
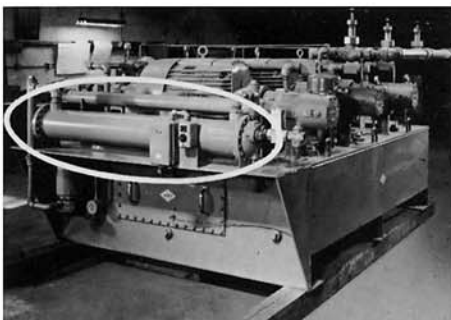

One Model F-604-AR-2P-CNTB heat exchanger cools the hydraulic drive winch unit used aboard a 1200 ton tuna purse seine vessel.

Fig. 5

A Model HF-806-AR-2P heat exchanger controls the temperature of the coolant for this eddy current drive.

Fig. 6

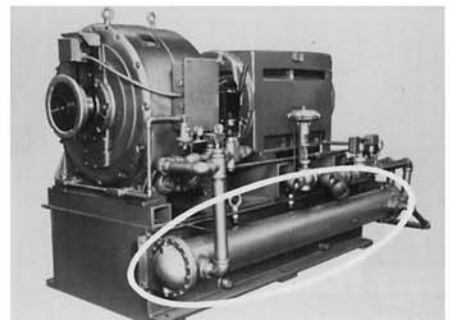

CONSTRUCTION FEATURES

STURDY BRACKET

Made of heavy gauge steel . . . adjustable for installation in various positions. Rotatable through 360 degrees.



All heat exchangers except 2 inch have drain plugs. CN and CNT units have zinc anodes which sacrificially corrode in salt water.

SMOOTH FLOW BONNET

Distributes fluid to tubes with minimum turbulence. One, two or four pass interchangeability.

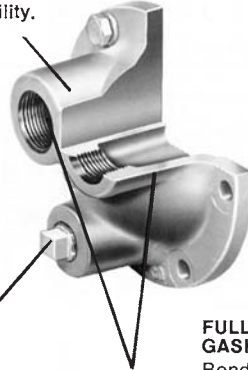

TUBES

On F and HF, tubes are high temperature bonded into tube sheets. On SSF and F-1000 series, tubes are rolled into tube sheets by electronic control.

FULL-FLOW OPENINGS

Adequately sized for minimum pressure drop. Flexible connections are recommended when vibration is present.

END HUB

End hub is high quality forging or casting. Full-flow opening is designed for minimum pressure drop.

BAFFLES

Segmented baffles available in five spacings for maximum heat transfer with minimum fluid pressure drop.

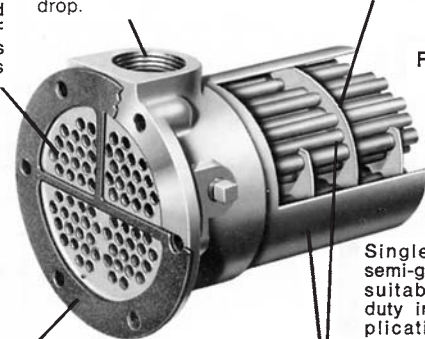

Fig. 7

FINISH

Single coat of grey, semi-gloss enamel paint suitable for outdoor duty in non-critical applications, and as a base for subsequent coats for severe duty or extended life.

FULL FACE GASKET

Bonded gasket for maximum pressure and temperature.

SHELL AND TUBE BUNDLE ASSEMBLY

Baffles precision stamped to close tolerances. Clearances between baffles and tubes, baffles and shell are minimum—to obtain maximum heat transfer. Available in various size combinations to suit heat transfer requirements.

TABLE 1

MODEL IDENTIFICATION						
TYPE CODE	SHELL DIAMETER CODE	SHELL LENGTH CODE	BAFFLE SPACING CODE	TUBE DIAMETER CODE	PASS CODE	OPTION CODE
F = fixed tube bundle with 150 psi 1040 kPa shell	2 = 2.12 in	01 = 9 in	H = 1.13 in	Y = 0.250 in OD	1P = one pass	CN = 90-10 copper nickel tube
HF = fixed tube bundle with 250 psi 1725 kPa shell	3 = 3.62 in	02 = 18 in	D = 2.25 in	R = 0.375 in OD	2P = two pass	CNT = 90-10 copper nickel tube and tube sheet
SSF = fixed tube bundle with 300 psi 2070 kPa shell and stainless steel materials	5 = 5.12 in	03 = 27 in	E = 4.50 in	C = 0.625 in OD	4P = four pass	B = brass bonnet
	6 = 6.12 in	04 = 36 in	A = 9.00 in			S = SAE straight thread
	8 = 8.25 in	05 = 45 in	T = 15 in (approx.)			O-Ring shell connections
	10 = 10.75 in	06 = 54 in				
		08 = 72 in				
		10 = 90 in				

NOTE A: F TYPE CODE not available in 2 and 8 SHELL DIAMETER CODE.

NOTE B: HF TYPE CODE not available in 10 SHELL DIAMETER CODE.

NOTE C: HF-2 TYPE CODE, SHELL DIAMETER CODE not available in 2P or 4P PASS CODE.

NOTE D: CN OPTION CODE available with 10 SHELL DIAMETER CODE only, all others are CNT OPTION CODE.

NOTE E: MODEL EXAMPLE—



TABLE 2

METRIC CONVERSIONS					
VARIABLE	PREFERRED		ALTERNATE		CONVERSION MULTIPLIER**
	SI UNIT	ABBREVIATION	UNIT	ABBREVIATION	
length	metre	m	millimetre	mm	0.001
mass	kilogram	kg	gram	g	0.001
time	second	s	hour*	hr	0.0002777
heat energy	joule	J	calorie*	cal	4.187
force	newton	N	kilogram-force*	kgf	9.81
power	watt	W	joule/second	J/s	1.0
pressure	newton/metre ²	N/m ²	kilopascal	kPa	1000
volume flow rate	cubic metre/second	m ³ /s	litre*	l	0.001
volume flow rate	cubic centimetre/second	cm ³ /s	litre*	l	1000
acceleration	metre/second ²	m/s ²	—	—	—

* does not conform to SI metric standard

** to convert to preferred, multiply alternate by CONVERSION MULTIPLIER

This catalog is dual dimensioned with the primary units being **U. S. customary (bold face type)** and the secondary dimensions being SI metric as defined in ASTM Designation: E380. Strict conformance to the SI metric standard produces some unfamiliar units in the tables and charts. Particular note should be made of the SI metric units of CAPACITY FACTOR (J/s-C = W/C) and SHIPPING WEIGHT (N). In the former case, the Joule (J) is the preferred unit of heat energy instead of the calorie and the preferred unit of weight or force is the Newton instead of the kilogram-force. Mass is related to force by the formula: force (N) = mass (g) x acceleration (9.8 m/s²). For reference, a tabulation of the metric units used in this catalog is provided as well as selected conversions to other metric units some of which do not conform to the SI standard.

F HF SSF Dimensions

2 SHELL DIA. CODE
1P PASS CODE

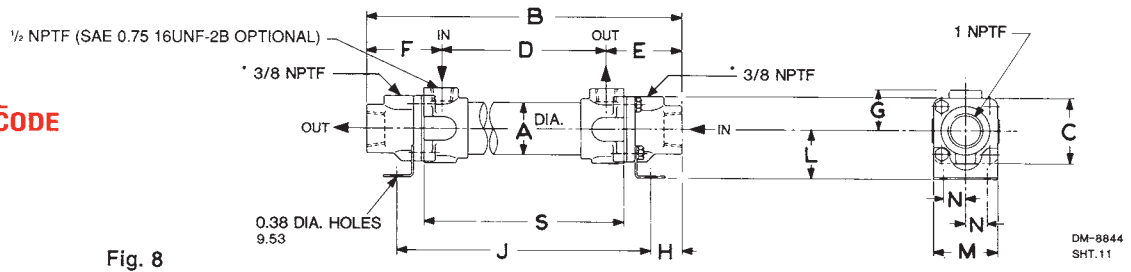

Fig. 8

3 SHELL DIA. CODE
1P PASS CODE

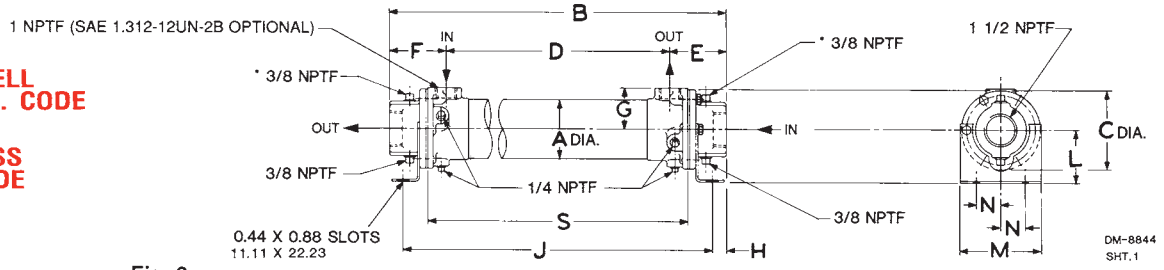

Fig. 9

3 SHELL DIA. CODE
2P PASS CODE

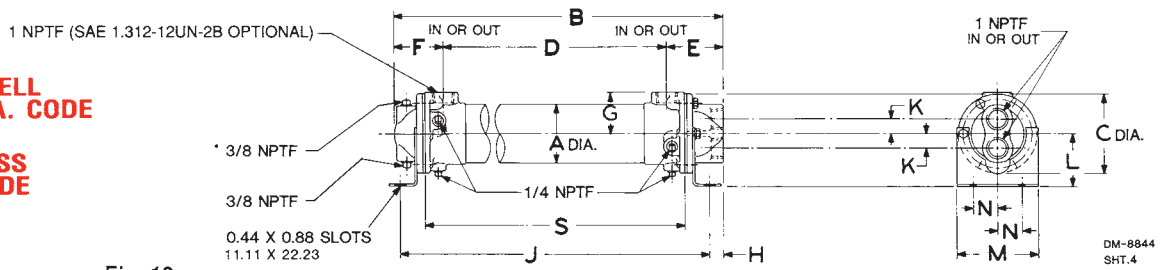

Fig. 10

3 SHELL DIA. CODE
4P PASS CODE

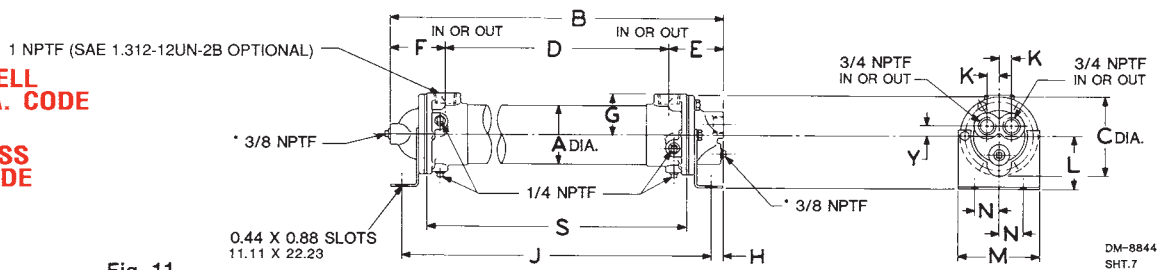

Fig. 11

TABLE 10

SHELL DIAMETER & SHELL LENGTH CODE	ALL UNITS										ONE PASS															
	A	C	D	G	J	L	M	N	S	H	B	E	F													
201	2.12	53.8	2.50	63.5	7.62	193.5	1.56	39.6	11.12	282.4	1.88	47.7	2.50	63.5	.88	22.3	9.00	228.6	1.13	28.7	13.38	339.8	2.88	73.1	2.88	73.1
202	2.12	53.8	2.50	63.5	16.62	422.1	1.56	39.6	20.12	512.6	1.88	47.7	2.50	63.5	.88	22.3	18.00	457.2	1.13	28.7	22.38	568.4	2.88	73.1	2.88	73.1
301	3.62	91.9	4.88	123.9	7.00	177.8	2.50	63.5	12.25	311.2	3.25	82.5	5.00	127.0	1.50	38.1	9.25	234.9	0.82	20.8	13.88	352.5	3.44	87.3	3.44	87.3
302	3.62	91.9	4.88	123.9	16.00	406.4	2.50	63.5	21.25	546.1	3.25	82.5	5.00	127.0	1.50	38.1	18.25	463.5	0.82	20.8	22.88	581.1	3.44	87.3	3.44	87.3
303	3.62	91.9	4.88	123.9	25.00	635.0	2.50	63.5	30.25	768.4	3.25	82.5	5.00	127.0	1.50	38.1	27.25	692.1	0.82	20.8	31.88	809.7	3.44	87.3	3.44	87.3
502	5.12	130.0	6.50	165.1	15.50	393.7	3.31	84.0	21.50	546.1	4.00	101.6	6.25	158.7	2.00	50.8	18.50	469.9	1.06	26.9	23.62	599.9	4.06	103.1	4.06	103.1
503	5.12	130.0	6.50	165.1	24.50	622.3	3.31	84.0	30.50	774.7	4.00	101.6	6.25	158.7	2.00	50.8	27.50	698.5	1.06	26.9	32.62	828.5	4.06	103.1	4.06	103.1
504	5.12	130.0	6.50	165.1	33.50	850.9	3.31	84.0	39.50	1003.3	4.00	101.6	6.25	158.7	2.00	50.8	36.50	927.1	1.06	26.9	41.62	1057.1	4.06	103.1	4.06	103.1
602	6.12	155.4	7.50	190.5	14.62	371.3	3.75	95.3	21.38	543.1	4.75	120.6	7.25	184.1	2.50	63.5	18.38	466.8	1.31	33.2	24.00	609.6	4.69	119.1	4.69	119.1
603	6.12	155.4	7.50	190.5	23.50	596.9	3.75	95.3	30.25	768.4	4.75	120.6	7.25	184.1	2.50	63.5	27.25	692.1	1.31	33.2	32.88	835.1	4.69	119.1	4.69	119.1
604	6.12	155.4	7.50	190.5	32.38	822.4	3.75	95.3	39.12	993.6	4.75	120.6	7.25	184.1	2.50	63.5	36.12	917.4	1.31	33.2	41.76	1060.7	4.69	119.1	4.69	119.1
606	6.12	155.4	7.50	190.5	50.50	1282.7	3.75	95.3	57.25	1454.2	4.75	120.6	7.25	184.1	2.50	63.5	54.25	1377.9	1.31	33.2	59.88	1520.9	4.69	119.1	4.69	119.1
608	6.12	155.4	7.50	190.5	68.38	1736.8	3.75	95.3	75.12	1908.0	4.75	120.6	7.25	184.1	2.50	63.5	72.12	1831.8	1.31	33.2	77.76	1975.1	4.69	119.1	4.69	119.1

(All dimensions are inches millimetres)

(Certified drawings are available upon request)

*Zinc anode only with CN and CNT option codes

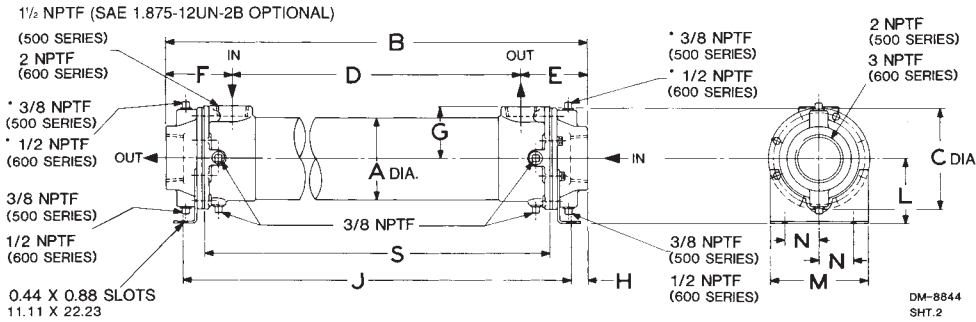

5 & 6 SHELL DIA. CODE
1P PASS CODE

Fig. 12

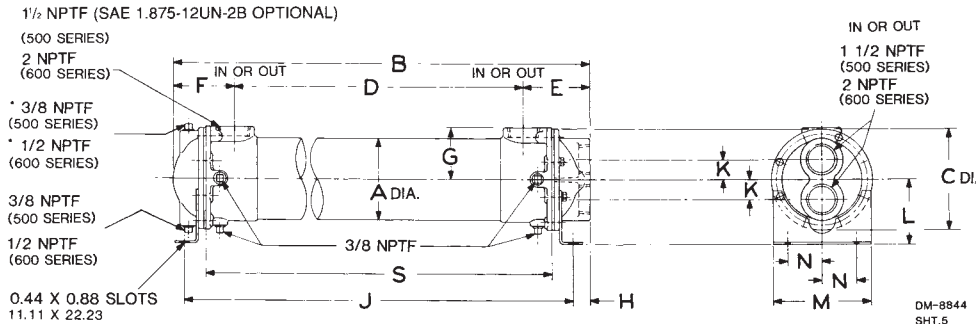

5 & 6 SHELL DIA. CODE
2P PASS CODE

Fig. 13

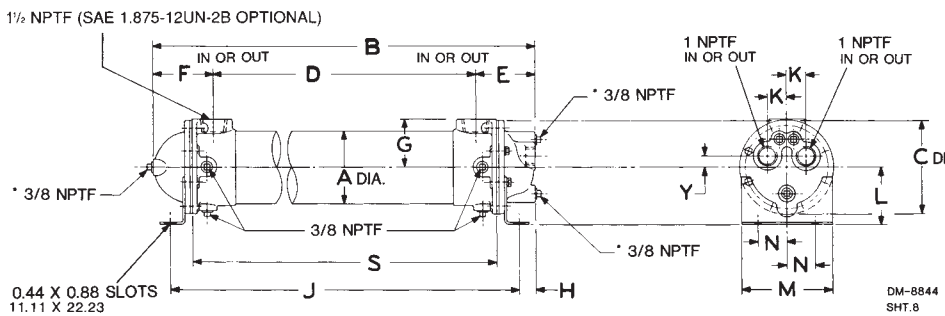

5 SHELL DIA. CODE
4P PASS CODE

Fig. 14

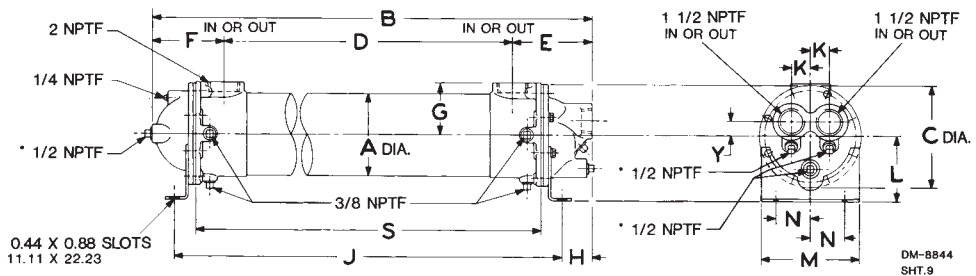

6 SHELL DIA. CODE
4P PASS CODE

Fig. 15

TWO PASS					FOUR PASS							SHELL DIAMETER & SHELL LENGTH CODE										
H	B	E	F	K	H	B	E	F	K	Y												
-	-	-	-	-	-	-	-	-	-	-	-	201										
-	-	-	-	-	-	-	-	-	-	-	-	202										
0.82	20.8	13.38	339.8	3.44	87.3	2.94	74.6	0.88	22.3	0.68	17.3	13.62	345.9	3.31	84.0	3.31	84.0	0.75	19.0	0.62	15.7	301
0.82	20.8	22.38	568.4	3.44	87.3	2.94	74.6	0.88	22.3	0.68	17.3	22.62	574.5	3.31	84.0	3.31	84.0	0.75	19.0	0.62	15.7	302
0.82	20.8	31.38	797.0	3.44	87.3	2.94	74.6	0.88	22.3	0.68	17.3	31.62	803.1	3.31	84.0	3.31	84.0	0.75	19.0	0.62	15.7	303
1.06	26.9	23.12	537.2	4.06	103.1	3.56	90.4	1.18	29.9	1.06	26.9	23.62	599.9	4.06	103.1	4.06	103.1	1.34	34.0	0.75	19.0	502
1.06	26.9	32.12	815.8	4.06	103.1	3.56	90.4	1.18	29.9	1.06	26.9	32.62	828.5	4.06	103.1	4.06	103.1	1.34	34.0	0.75	19.0	503
1.06	26.9	41.12	1044.4	4.06	103.1	3.56	90.4	1.18	29.9	1.06	26.9	41.62	1057.1	4.06	103.1	4.06	103.1	1.34	34.0	0.75	19.0	504
1.31	33.2	23.50	596.9	4.69	119.1	4.19	106.4	1.50	38.1	2.25	57.2	25.38	644.6	5.56	141.2	5.19	131.8	1.41	35.8	1.06	26.9	602
1.31	33.2	32.38	822.4	4.69	119.1	4.19	106.4	1.50	38.1	2.25	57.2	34.25	869.9	5.56	141.2	5.19	131.8	1.41	35.8	1.06	26.9	603
1.31	33.2	41.26	1048.0	4.69	119.1	4.19	106.4	1.50	38.1	2.25	57.2	43.13	1095.5	5.56	141.2	5.19	131.8	1.41	35.8	1.06	26.9	604
1.31	33.2	59.38	1508.2	4.69	119.1	4.19	106.4	1.50	38.1	2.25	57.2	61.25	1555.7	5.56	141.2	5.19	131.8	1.41	35.8	1.06	26.9	606
1.31	33.2	77.26	1962.4	4.69	119.1	4.19	106.4	1.50	38.1	2.25	57.2	79.13	2009.9	5.56	141.2	5.19	131.8	1.41	35.8	1.06	26.9	608

(Certified drawings are available upon request)

*Zinc anode only with CN and CNT option codes.

F HF SSF Dimensions

8 SHELL DIA. CODE
1P PASS CODE

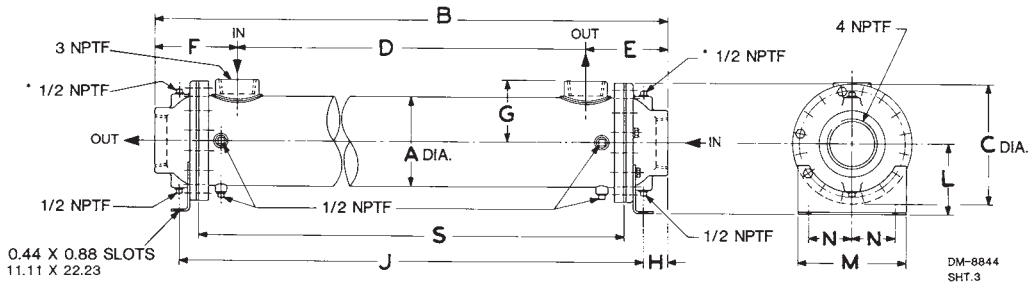

Fig. 16

8 SHELL DIA. CODE
2P PASS CODE

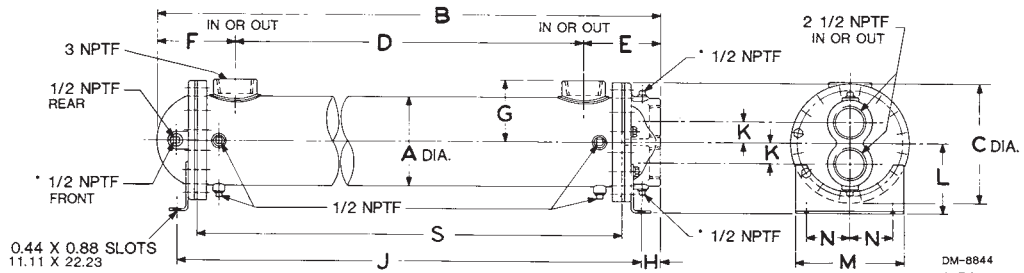

Fig. 17

8 SHELL DIA. CODE
4P PASS CODE

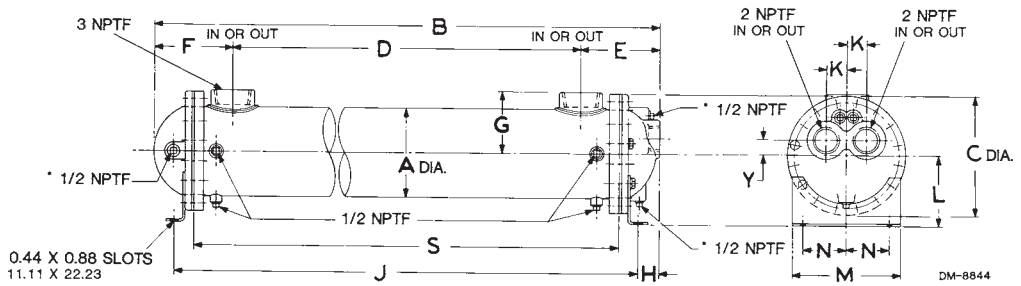

Fig. 18

TABLE 11

SHELL DIAMETER & SHELL LENGTH CODE	ALL UNITS										ONE PASS			
	A	C	D	G	J	L	M	N	S	H	B	E	F	
802	8.25 209.5	11.00 279.4	12.00 304.8	5.62 142.7	22.94 582.7	6.50 165.1	10.00 254.0	4.00 101.6	19.12 485.6	2.15 54.6	27.24 691.8	7.62 193.5	7.62 193.5	
803	8.25 209.5	11.00 279.4	21.00 533.4	5.62 142.7	31.94 811.3	6.50 165.1	10.00 254.0	4.00 101.6	28.12 714.2	2.15 54.6	36.24 920.4	7.62 193.5	7.62 193.5	
804	8.25 209.5	11.00 279.4	30.00 762.0	5.62 142.7	40.94 1039.9	6.50 165.1	10.00 254.0	4.00 101.6	37.12 942.8	2.15 54.6	45.24 1149.0	7.62 193.5	7.62 193.5	
805	8.25 209.5	11.00 279.4	39.00 990.6	5.62 142.7	49.94 1268.5	6.50 165.1	10.00 254.0	4.00 101.6	46.12 1171.4	2.15 54.6	54.24 1377.6	7.62 193.5	7.62 193.5	
806	8.25 209.5	11.00 279.4	48.00 1219.2	5.62 142.7	58.94 1497.1	6.50 165.1	10.00 254.0	4.00 101.6	55.12 1400.0	2.15 54.6	63.24 1606.2	7.62 193.5	7.62 193.5	
808	8.25 209.5	11.00 279.4	66.00 1676.4	5.62 142.7	76.94 1954.3	6.50 165.1	10.00 254.0	4.00 101.6	73.12 1857.2	2.15 54.6	81.24 2063.4	7.62 193.5	7.62 193.5	
810	8.25 209.5	11.00 279.4	84.00 2133.6	5.62 142.7	94.94 2411.5	6.50 165.1	10.00 254.0	4.00 101.6	91.12 2314.4	2.15 54.6	99.24 2520.6	7.62 193.5	7.62 193.5	
1005	10.75 273.0	14.88 377.9	34.12 866.6	10.75 273.0	25.00 635.0	8.00 203.2	12.25 311.1	5.00 127.0	46.12 1171.4	17.38 441.4	59.88 1520.9	12.88 327.1	12.88 327.1	
1006	10.75 273.0	14.88 377.9	43.12 1095.2	10.75 273.0	34.00 863.6	8.00 203.2	12.25 311.1	5.00 127.0	55.12 1400.0	17.38 441.4	68.88 1749.5	12.88 327.1	12.88 327.1	
1008	10.75 273.0	14.88 377.9	61.12 1552.4	10.75 273.0	52.00 1320.8	8.00 203.2	12.25 311.1	5.00 127.0	73.12 1857.2	17.38 441.4	86.88 2206.7	12.88 327.1	12.88 327.1	
1010	10.75 273.0	14.88 377.9	79.12 2009.6	10.75 273.0	70.00 1778.0	8.00 203.2	12.25 311.1	5.00 127.0	91.12 2314.4	17.38 441.4	104.88 2663.9	12.88 327.1	12.88 327.1	

(Certified drawings are available upon request)

(All dimensions are inches millimetres.)
*Zinc anode only with CN and CNT option codes.

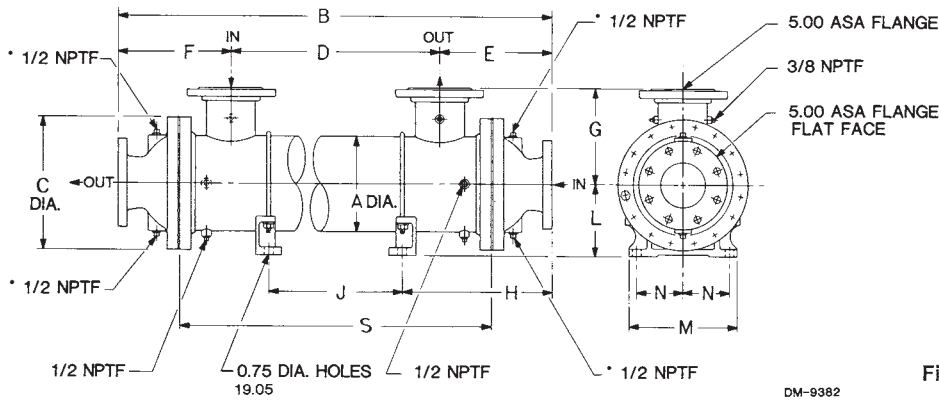

Fig. 19

DM-9382

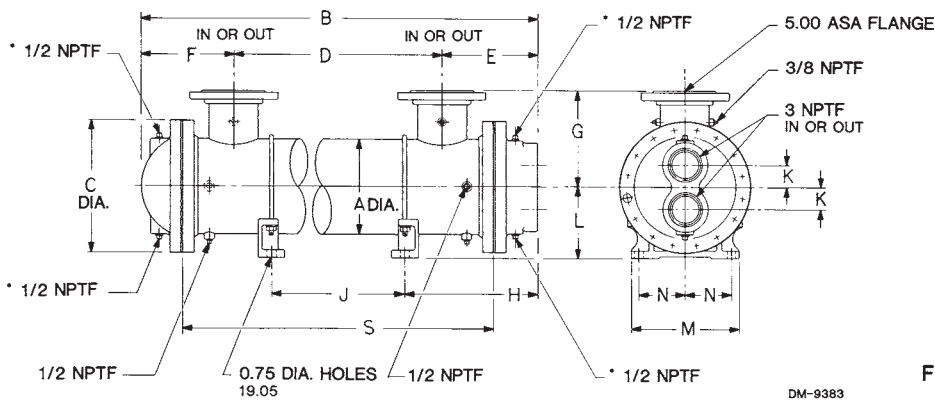

Fig. 20

DM-9383

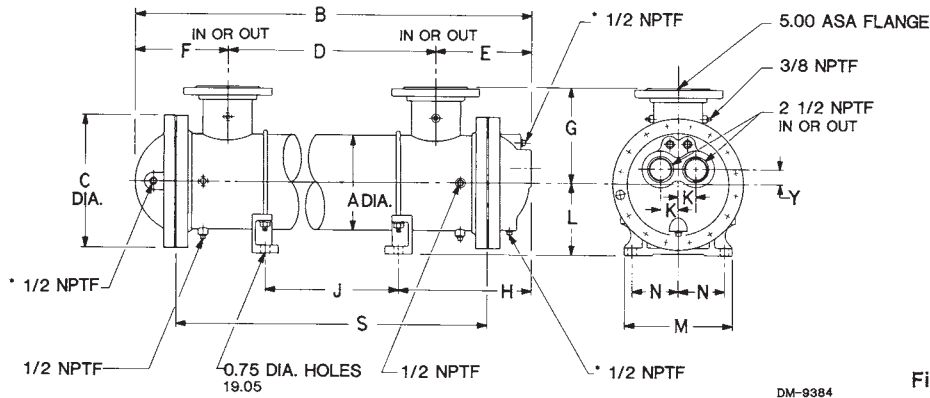

Fig. 21

DM-9384

TWO PASS									FOUR PASS									SHELL DIAMETER & SHELL LENGTH CODE				
H	B	E	F	K	H	B	E	F	K	Y												
1.65	41.9	26.24	666.4	7.12	180.8	7.12	180.8	1.88	47.7	1.65	41.9	26.24	666.4	7.12	180.8	7.12	180.8	1.88	47.7	1.38	35.0	802
1.65	41.9	35.24	895.0	7.12	180.8	7.12	180.8	1.88	47.7	1.65	41.9	35.24	895.0	7.12	180.8	7.12	180.8	1.88	47.7	1.38	35.0	803
1.65	41.9	44.24	1123.6	7.12	180.8	7.12	180.8	1.88	47.7	1.65	41.9	44.24	1123.6	7.12	180.8	7.12	180.8	1.88	47.7	1.38	35.0	804
1.65	41.9	53.24	1352.2	7.12	180.8	7.12	180.8	1.88	47.7	1.65	41.9	53.24	1352.2	7.12	180.8	7.12	180.8	1.88	47.7	1.38	35.0	805
1.65	41.9	62.24	1580.8	7.12	180.8	7.12	180.8	1.88	47.7	1.65	41.9	62.24	1580.8	7.12	180.8	7.12	180.8	1.88	47.7	1.38	35.0	806
1.65	41.9	80.24	2038.0	7.12	180.8	7.12	180.8	1.88	47.7	1.65	41.9	80.24	2038.0	7.12	180.8	7.12	180.8	1.88	47.7	1.38	35.0	808
1.65	41.9	98.24	2495.2	7.12	180.8	7.12	180.8	1.88	47.7	1.65	41.9	98.24	2495.2	7.12	180.8	7.12	180.8	1.88	47.7	1.38	35.0	810
15.38	390.6	55.63	1413.0	10.88	276.3	10.63	270.0	2.50	63.5	15.38	390.6	55.63	1413.0	10.88	276.3	10.63	270.0	2.00	50.8	1.75	44.4	1005
15.38	390.6	64.63	1641.6	10.88	276.3	10.63	270.0	2.50	63.5	15.38	390.6	64.63	1641.6	10.88	276.3	10.63	270.0	2.00	50.8	1.75	44.4	1006
15.38	390.6	82.63	2098.8	10.88	276.3	10.63	270.0	2.50	63.5	15.38	390.6	82.63	2098.8	10.88	276.3	10.63	270.0	2.00	50.8	1.75	44.4	1008
15.38	390.6	100.63	2556.0	10.88	276.3	10.63	270.0	2.50	63.5	15.38	390.6	100.63	2556.0	10.88	276.3	10.63	270.0	2.00	50.8	1.75	44.4	1010

(Certified drawings are available upon request)

*Zinc anode only with CN and CNT option codes.

Company Profile

Young Touchstone, a Wabtec company, with over 75 years of heat transfer experience, has steadily become one of the manufacturing leaders of radiators, oil coolers, heat exchangers and charge-air-coolers. Superior quality, continuous improvement, efficient production and productive ideas and design capabilities have provided Young Touchstone a competitive advantage in the marketplace. These market advantages have allowed the company to become a manufacturing leader in the rail, off-highway, department of defense, industrial and power generation industries. Young Touchstone products become standards on which the industry depends. The company's high quality products are benchmarks in the marketplace.

With over 100 patents in heat exchanger and cooling system design, Young Touchstone has become the leader in cooling system design for large diesel and gas engines. Young Touchstone prides itself to be the global leader in the design, manufacture, and marketing of heavy duty heat transfer components and systems that meet or exceed our customer's expectations for performance, quality, delivery, and cost.

Young Touchstone ISO 9001 certified facilities provide both pre-configured and custom engineered products supported by extensive R&D, engineering, and manufacturing operations with designs based upon:

- Wabtec's Quality and Performance System (QPS) Value Systems Mapping for Continuous Improvement

- Wabtec's Customer Focused Product Development System (PDS)
- Finite Element Analysis (FEA) Trained Engineers
- EDS I-deas Product Design and Unigraphics CAD Software Programs
- Simulation and Software Design Tools Compatible for Computation Fluid Dynamics (CFD)
- State-of-the-Art Prototype and Production Testing Laboratories
- Life Cycle testing for Thermal, Pressure, Vibration, Shock, Salt Spray, Ambient, Oil/Water, Oil/Air, Water/Air and Air/Air Environments

Advanced design technology has led to Young Touchstone market exclusives in the power generation and rail markets such as the proven Mechanical Bond Core and superior O-Ring Tank Sealing utilized in products available for all industry segments.

All Young Touchstone products are field supported by exclusive industry leading application engineering software designed to provide cost effective, on the site, performance proven solutions for all radiator, oil cooler, charge-air-cooler, and heat exchanger products.

With U.S. operations headquartered in Jackson, Tennessee plus additional operations in Racine, Wisconsin and Lexington, Tennessee, Young Touchstone facilities total over 400,000 square feet. Look to Young Touchstone, a powerful market leader in heat transfer products, providing choice and a measurable difference in the marketplace.

Locate a representative at YoungTouchstone.com or contact our sales and marketing offices in Racine, Wisconsin at 262-639-1010 for quality product, service, and responsive support.



www.youngtouchstone.com

Jackson, Tennessee
200 Smith Lane
Jackson, TN 38308

PH: 731-424-5045
FX: 731-424-4625
TF: 1-800-238-8230

Lexington, Tennessee
1000 Young Drive
Lexington, TN 38351

PH: 731-968-3617
FX: 731-967-7752

Racine, Wisconsin
Sales office
2825 Four Mile Road
Racine, WI 53404

PH: 262-639-1010
FX: 262-639-1013